

3CCD Color Video Camera

Operating Instructions

BRC-300/300P

Owner's Record

The model and serial numbers are located on the bottom. Record these numbers in the spaces provided below. Refer to these numbers whenever you call upon your Sony dealer regarding this product.

Model No. _____

Serial No. _____

WARNING

To prevent fire or shock hazard, do not expose the unit to rain or moisture.

To avoid electrical shock, do not open the cabinet. Refer servicing to qualified personnel only.

WARNING

Use the Sony MPA-AC1 AC power adapter provided with this equipment as a power supply source. Any other power sources may result in hazards such as a fire. This product has no power switch.

Disconnect device of this equipment is the mains plug of the AC adapter.

The mains plug on this equipment must be used to disconnect mains power.

Please ensure that the socket outlet is installed near the equipment and shall be easily accessible.

In the event of abnormal operations, disconnect the mains plug.

WARNING (For Installers only)

Instruction for installing the equipment on the ceiling: After the installation, ensure the connection is capable of supporting four times the weight of the equipment downwards.

IMPORTANT

Nameplate is located on the bottom.

ATTENTION

The electromagnetic fields at the specific frequencies may influence the picture of this unit.

For customers in the U.S.A.

This equipment has been tested and found to comply with the limits for a Class B digital device, pursuant to Part 15 of the FCC Rules. These limits are designed to provide reasonable protection against harmful interference in a residential installation. This equipment generates, uses, and can radiate radio frequency energy and, if not installed and used in accordance with the instructions, may cause harmful interference to radio communications. However, there is no guarantee that interference will not occur in a particular installation. If this equipment does cause harmful interference to radio or television reception, which can be determined by

turning the equipment off and on, the user is encouraged to try to correct the interference by one or more of the following measures:

- Reorient or relocate the receiving antenna.
- Increase the separation between the equipment and receiver.
- Connect the equipment into an outlet on a circuit different from that to which the receiver is connected.
- Consult the dealer or an experienced radio/TV technician for help.

If you have any questions about this product, you may call:

*Sony's Business Information Center (BIC) at
1-800-686-Sony (7669)*

*or Write to: Sony Customer Information Services
Center*

*6900-29, Daniels Parkway, PMB 330
Fort Myers, Florida 33912*

Declaration of Conformity

Trade Name: SONY
Model No: BRC-300
Responsible Party: Sony Electronics Inc.
Address: 16450 W. Bernardo Dr, San
Diego, CA 92127 U.S.A.

Telephone Number: 858-942-2230

This device complies with part 15 of the FCC Rules. Operation is subject to the following two conditions:

- (1) This device may not cause harmful interference, and
- (2) this device must accept any interference received, including interference that may cause undesired operation.

You are cautioned that any changes or modifications not expressly approved in this manual could void your authority to operate this equipment.

The shielded interface cable recommended in this manual must be used with this equipment in order to comply with the limits for a digital device pursuant to Subpart B of Part 15 of FCC Rules.

INTERFACE CABLE

This device requires shielded interface cables to comply with FCC emission limits.

Notice for CCFC-M100 Optical Fiber Cable

Only trained and qualified personnel should be allowed to install this equipment with the cable.

WARNING :

The cable is rated flammability class VW-1 and may be for indoor use only in some countries. Use appropriate alternative cables in accordance with the regulations and laws for each country taking the application and environment into account.

Table of Contents

Getting Started

Precautions	5
Typical CCD Phenomena	5

Overview

Features	6
System Components	7
Supplied Components and Accessories	7
Optional Products	8
System Configuration	10
Operating a BRC-300/300P Camera Using the Supplied Remote Commander	10
Operating a BRC-300/300P Camera Using the RM-BR300 Remote Control Unit	10
Operating Multiple BRC-300/300P Cameras Us- ing the RM-BR300 Remote Control Unit	11
Operating a BRC-300/300P Camera from a Long Distance	12
Operating Multiple BRC-300/300P Cameras from a Long Distance	13
Using BRC-300/300P Cameras and VISCA-con- trollable Cameras in the Same System	14
Location and Function of Parts	15
Camera	15
Remote Commander (supplied)	17
RM-BR300 Remote Control Unit (not supplied)	18
BRU-300/300P Optical Multiplex Unit (not supplied)	21
BRBK-301 Analog RGB Component Card (not supplied)	22
BRBK-302 SDI Card (not supplied)	22
BRBK-303 Optical Multiplex Card (not supplied)	22

Adjusting and Setting With Menus

About On-Screen Menus	23
Main Menu	23
Setting Menu	23
Operation Through Menus	24
Menu Operation Using the Supplied Remote Commander	24
Menu Operation Using the RM-BR300 Remote Control Unit	25
EXPOSURE Menu	26
FOCUS Menu	27
WHITE BALANCE Menu	27
PAN TILT ZOOM Menu	28
PICTURE Menu	29
SYSTEM Menu	29
ANALOG OUT Menu	30

Operation Using the Supplied Remote Commander

Turning on the Power	31
Pan/Tilt and Zoom Operation	31
Panning and Tilting	31
Zooming	32
Operating Multiple Cameras with the Remote Commander	32
Adjusting the Camera	33
Focusing on a Subject	33
Shooting with Back Lighting	33
Storing the Camera Settings in Memory – Presetting Feature	34

Operation Using the RM-BR300 Remote Control Unit

Turning on the Power	35
Operating Multiple Cameras	35
Pan/Tilt and Zoom Operation	36
Panning and Tilting	36
Zooming	37
Adjusting the Camera	38
Focusing on a Subject	38
Shooting with Back Lighting	38
Adjusting the White Balance	38
Adjusting the Brightness	39
Storing the Camera Settings in Memory – Presetting Feature	40

Installation and Connections

Installation	42
Attaching an Interface Card	42
Installing the Camera	42
Installing the Camera on the Ceiling	43
Connections	46
Connecting to an AC Outlet	46
Connecting the RM-BR300 Remote Control Unit	47
Connecting a Video Monitor, VTR, etc. Equipped with the Composite Video Input Connector ...	48
Connecting a Video Monitor, VTR, etc. Equipped with the S-Video Input Connector	48
Connecting a Device Equipped with VISCA RS-232C Connector	49
Connecting a Device Equipped with VISCA RS-422 Connector	49
Connecting a Video Monitor Equipped with Analog RGB/Component Connectors	50
Connecting a VTR Equipped with SDI Input Connector	51
Connecting the BRU-300/300P Optical Multiplex Unit	51
Connecting a Video Switcher	52
Connecting a Sync Signal Generator	53

Appendix

List of Messages	54
Troubleshooting	55
Menu Configuration	57
Presetting Items	59
Specifications	60
Dimensions	61
Pin Assignments	64
Wiring Diagram of VISCA RS-422 Connection	67
Using the VISCA RS-422 Connector Plug	68

Precautions

Operating or storage location

Operating or storing the camera in the following locations may cause damage to the camera:

- Extremely hot or cold places (Operating temperature: 0°C to +35°C [32°F to 95°F])
- Exposed in direct sunlight for a long time, or close to heating equipment (e.g., near heaters)
- Close to sources of strong magnetism
- Close to sources of powerful electromagnetic radiation, such as radios or TV transmitters
- Locations subject to strong vibration or shock

Ventilation

To prevent heat buildup, do not block air circulation around the camera.

Transportation

When transporting the camera, repack it as originally packed at the factory or in materials equal in quality.

Cleaning

- Use a blower to remove dust from the lens or optical filter.
- Use a soft, dry cloth to clean the external surfaces of the camera. Stubborn stains can be removed using a soft cloth dampened with a small quantity of detergent solution, then wipe dry.
- Do not use volatile solvents such as alcohol, benzene or thinners as they may damage the surface finishes.

Maintenance

The camera mechanism may cause abnormal noise due to wear and lubrication loss after a long period of use. To maintain optimum performance, we recommend periodical maintenance. If abnormal noise occurs, consult with your Sony dealer.

Note on laser beams

Laser beams may damage a CCD. You are cautioned that the surface of a CCD should not be exposed to laser beam radiation in an environment where a laser beam device is used.

Typical CCD Phenomena

The following phenomena may appear on the monitor screen while you are using the BRC-300/300P color video camera. These phenomena stem from the high sensitivity of the CCD image sensors, and do not indicate a fault within the camera.

Vertical smear

A “smear” may appear to extend vertically from very bright subjects, as shown below.

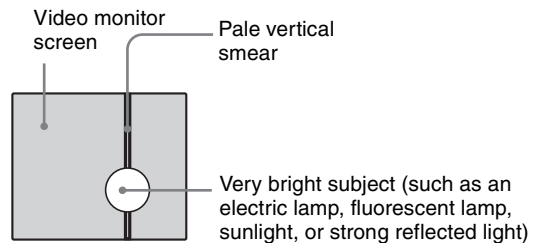

This phenomenon is common to CCD imaging elements using an interline transfer system, and is caused when electric charge induced by infrared radiation deep within the photo sensor is transferred to the resistors.

Aliasing

When shooting fine stripes, straight lines or similar patterns, the lines may become slightly jagged.

Blemishes

A CCD image sensor consists of an array of individual picture elements (pixels). A malfunctioning sensor element will show up as a single pixel blemish in the image. This is generally not a problem.

White speckles

When you shoot a poorly illuminated object at a high temperature, small white dots may appear all over the entire screen image.

Features

Compact, 3CCD video camera with built-in pan/tilt/zoom functions

- The camera integrates the 3CCD camera block, pan/tilt mechanism, and 12-magnification optical zoom with 4-magnification digital zoom in a compact body. The compactness and integration allow the camera versatile usage.
- The camera is provided with a wide-angle pan/tilt mechanism of $\pm 170^\circ$ horizontally, 90° upward and 30° downward, which enables wide-range remote shooting.
- The new pan/tilt mechanism enabling smooth camera movement even at low speed realizes a minimum pan/tilt speed of 0.25° per second.
- The pan/tilt mechanism is remarkably quiet, even at the maximum pan/tilt speed of 60° per second.

Mega-pixel 3CCD camera allowing high image quality and high-resolution remote shooting

- The camera incorporates three 1/4.7 type Advanced HAD* CCDs containing 1,070,000 picture elements in total.
 - * HAD is an abbreviation of Hole-Accumulated Diode.
Advanced HAD is a trademark of Sony Corporation.
- The camera realizes the high-quality image and high resolution, having a minimum illumination of 7 lx, horizontal resolution of 600 TV lines, and signal-to-noise ratio of more than 50 dB. In addition, the use of a primary-color optical prism enables shooting with superior color reproduction.
- A fine image is obtained by employing a newly-developed DSP of 14-bit A/D conversion for signal processing. This also greatly reduces digital noise and is effective for shooting at low illumination and shooting of black subjects.
- The aspect ratio of the camera image is selectable between 4:3 or 16:9. In addition, an optional wide conversion lens can be attached to the camera, allowing use in various shooting conditions.

Built-in interface card slot

The camera is equipped with an interface card slot for the optional BRBK-301 Analog RGB Component Card, BRBK-302 SDI Card or BRBK-303 Optical Multiplex Card. Use of these interface cards gives the camera the capability of having various image output formats.

Long-distance image transmission and pan/tilt/zoom control

- Combined use of the BRBK-303 Optical Multiplex Card, CCFC-M100 Optical Fiber Cable and BRU-300/300P Optical Multiplex Unit, and Sony's unique camera connection technology and optical digital multiplex transmission technology allows short to long distance (up to 500 m, or 1,640 feet) transmission of camera images and pan/tilt/zoom control signals. Use of the optical fiber cable enables an economical and easy system configuration for long distance.
- The supplied ceiling bracket allows installation of the camera on a ceiling.

VISCA camera protocol supported

- The camera is equipped with both RS-232C and RS-422 communication interfaces. As the camera supports the industry-standard VISCA camera protocol, up to 7 cameras can be connected and remotely controlled at a high communication speed of 38,400 bps.
- The optional RM-BR300 Remote Control Unit allows easy camera operations.
- The VISCA protocol allows use of cameras and controllers of other manufacturers together with those of Sony.

External video sync function

The camera is equipped with an external video sync function to synchronize the camera images on multiple cameras. The camera also has a composite video output connector and S video output connector as standard equipment.

Tally lamp

The tally lamp of the camera allows you to make sure it is selected at a glance.

Mounted circuit board using lead-free solder

Lead-free solder is used for the circuit boards of the camera for environmental reasons.

System Components

In order to support multiple system configurations, a variety of optional products are available for the BRC-300/300P 3CCD Color Video Camera. This section introduces these optional products as well as the accessories supplied with the camera.

Supplied Components and Accessories

Before using the camera, make sure you have the following components and accessories supplied.

Camera (1)

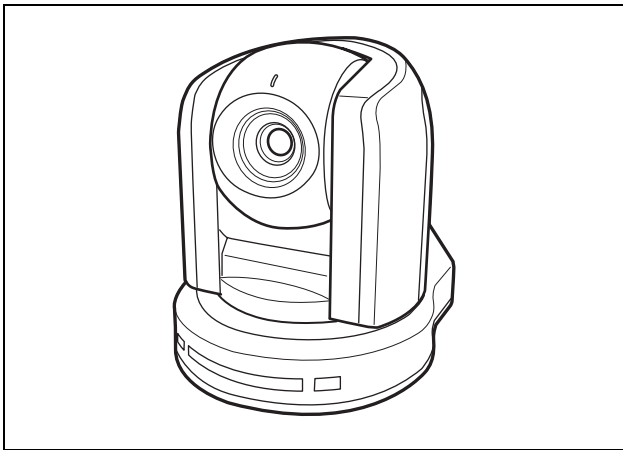

AC power adaptor MPA-AC1 (Sony) (1)

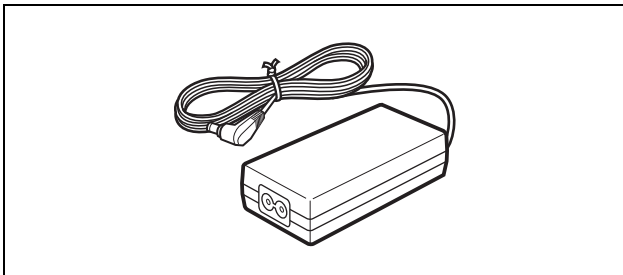

AC power cord (1)

USA and Canadian model

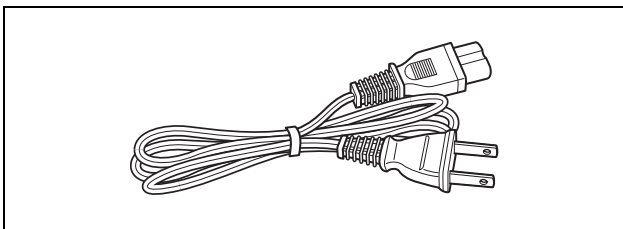

European model

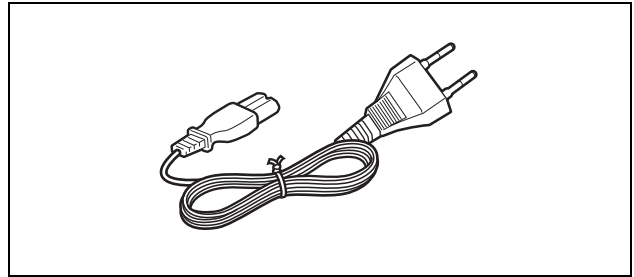

Remote commander (1)

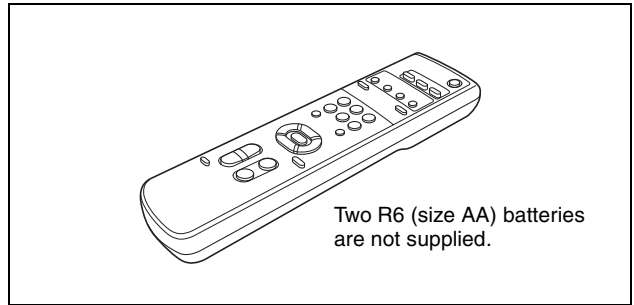

Ceiling bracket (A) (1)

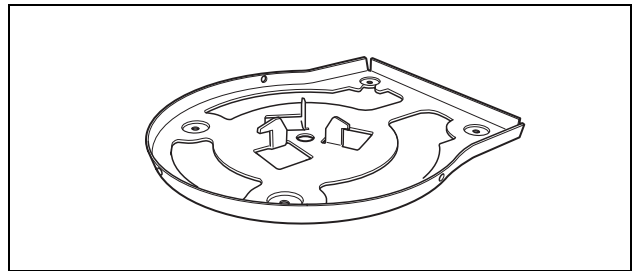

Ceiling bracket (B) (1)

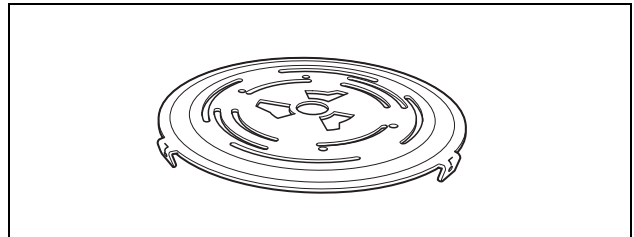

Wire rope (1)

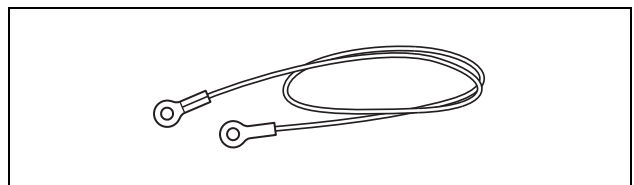

Screw +M3 × 8 (7)

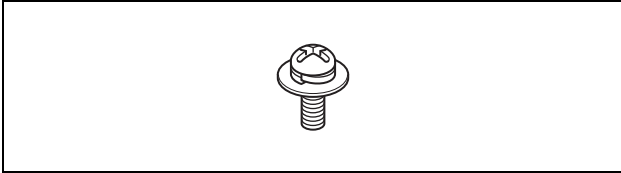

RS-422 connector plug (1)

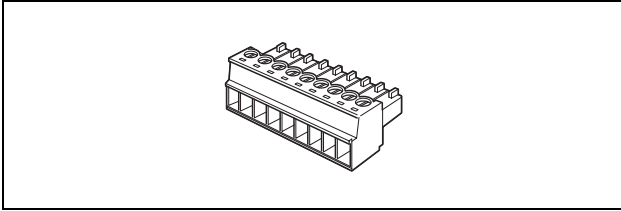

Operating Instructions (1)

Optional Products

RM-BR300 Remote Control Unit

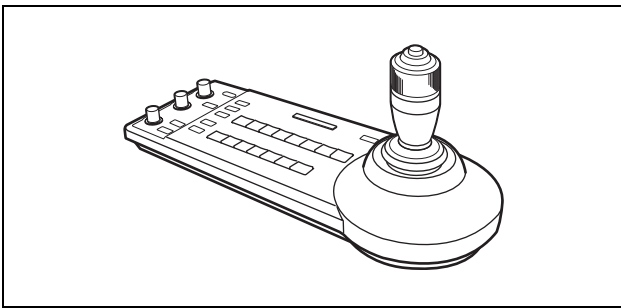

The joystick of the remote control unit allows you comfortable pan/tilt and zoom operations. The remote control unit also allows remote operation of up to seven cameras.

Supplied accessories: AC power adaptor (1), AC power cord (1), RS-232C connecting cable (3 m) (1), RS-422 connector plug (2)

BRU-300/300P Optical Multiplex Unit

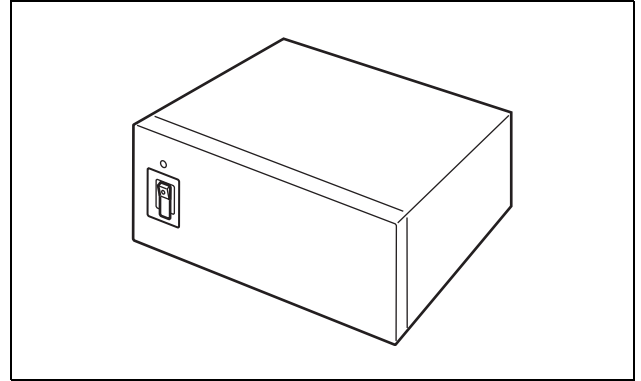

The optical multiplex unit allows a connection up to of 500 m (1,640 feet) using the CCFC-M100 2-core optical fiber cable.

Supplied accessories: AC power cord (1), RS-232C connecting cable (3 m) (1), RS-422 connector plug (1)

CCFC-M100 Optical Fiber Cable

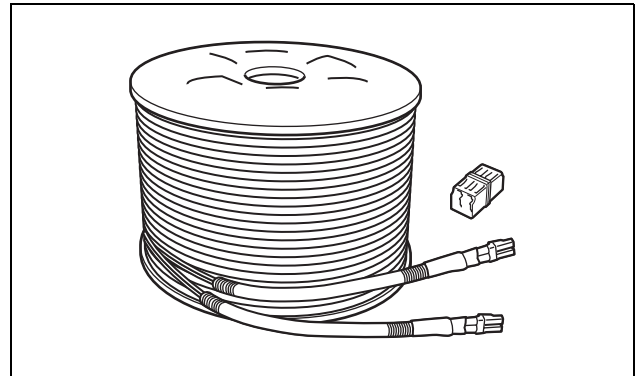

This is a 2-core multi-mode optical fiber cable of 100 m (328 feet) long.

Supplied accessories: extension plug

BRBK-301 Analog RGB Component Card

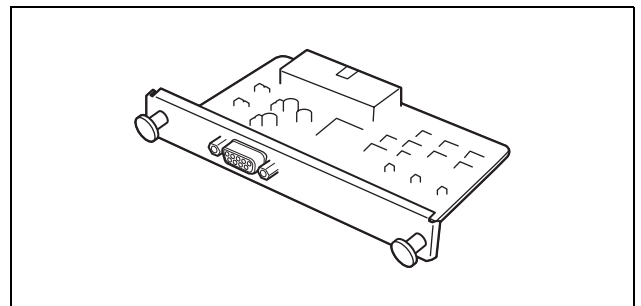

Insert the card into the camera or the Optical Multiplex Unit to allow output of an analog video signal such as the composite video, S video, component video and RGB signals.

BRBK-302 SDI Card

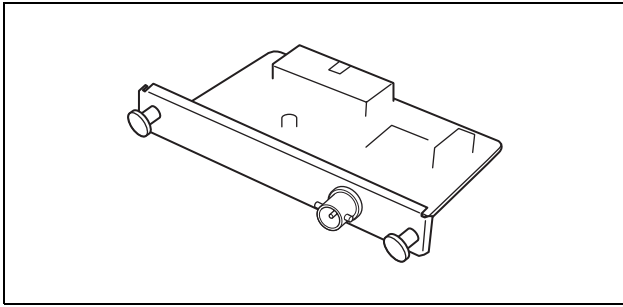

Insert the card into the camera or the Optical Multiplex Unit to allow output of a signal conforming to SMPTE259M serial digital interface standards.

BRBK-303 Optical Multiplex Card

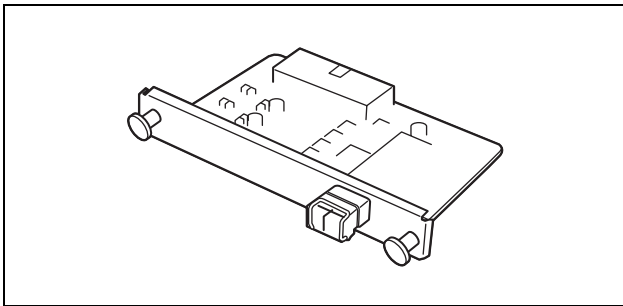

Insert the card into the camera to allow high-bit multiplex transfer via optical fiber (video, external video sync and control signals).

Video Switcher (commercially available)

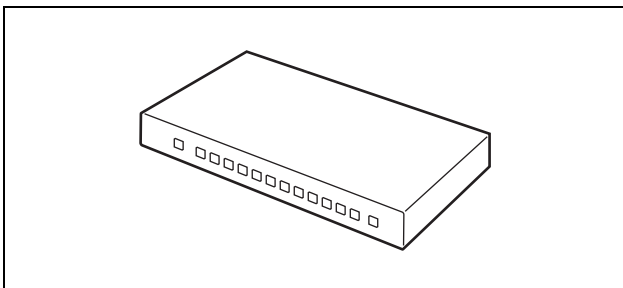

It switches the video signal input of multiple cameras.

System Configuration

The BRC-300/300P 3CCD Color Video Camera has various system configuration capabilities using optional products. This section describes six typical system examples with the required components and the main usage of each system.

Operating a BRC-300/300P Camera Using the Supplied Remote Commander

This system allows you:

To operate the camera readily from a short distance

System configuration

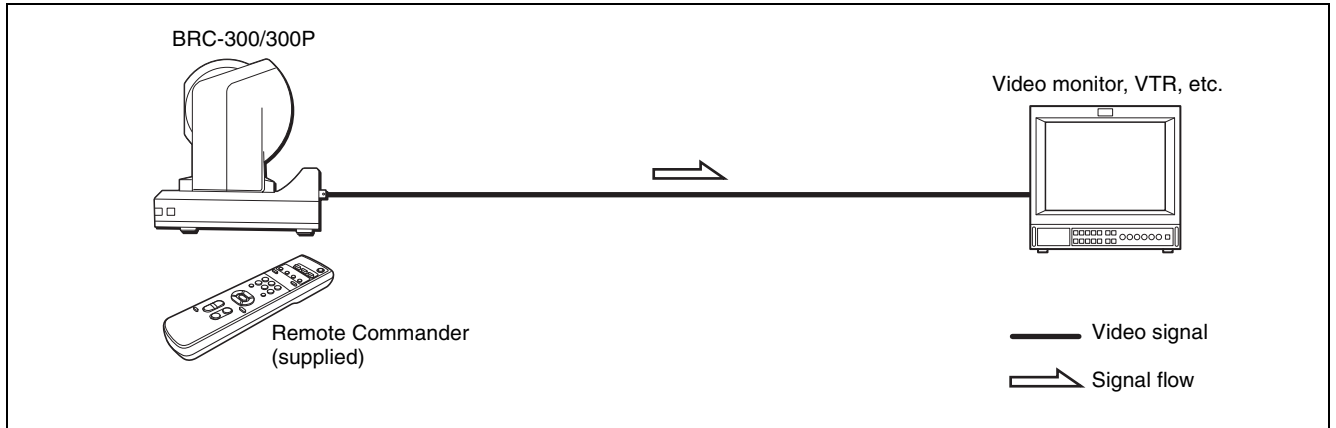

Operating a BRC-300/300P Camera Using the RM-BR300 Remote Control Unit

This system allows you:

To perform pan/tilt and zoom operations comfortably using the joystick of the Remote Control Unit

System configuration

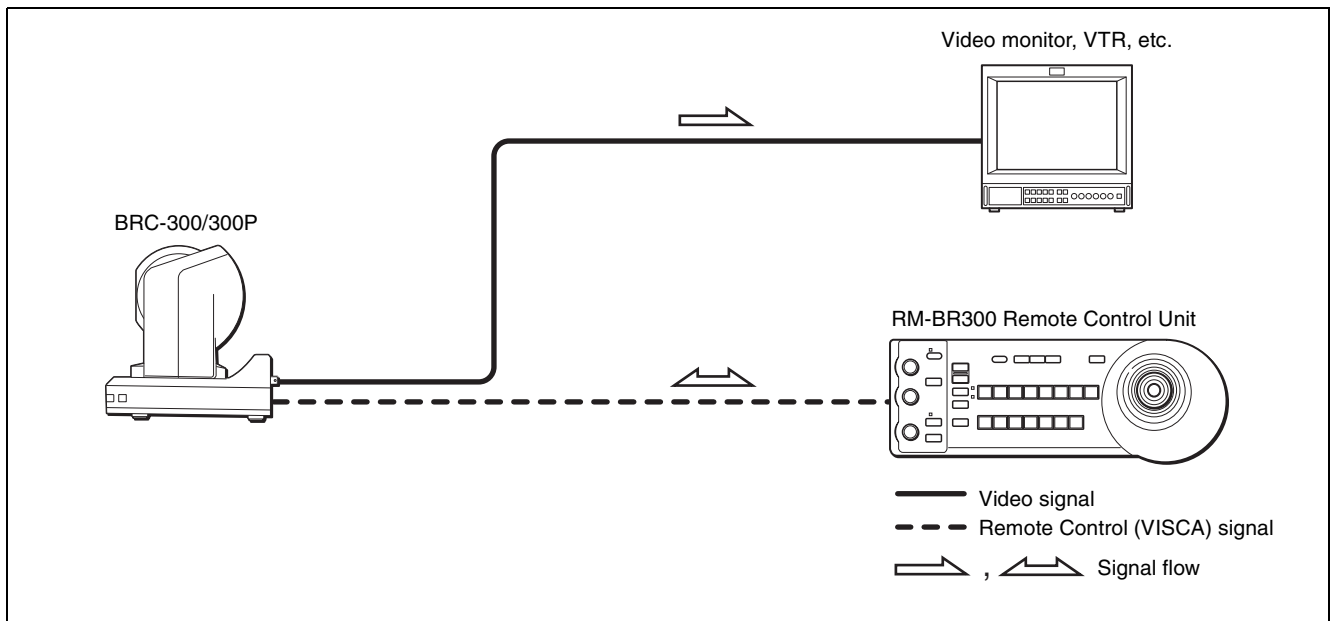

Operating Multiple BRC-300/300P Cameras Using the RM-BR300 Remote Control Unit

This system allows you:

- To operate up to seven cameras remotely using a single Remote Control Unit
- To perform pan/tilt and zoom operations comfortably using the joystick

System configuration

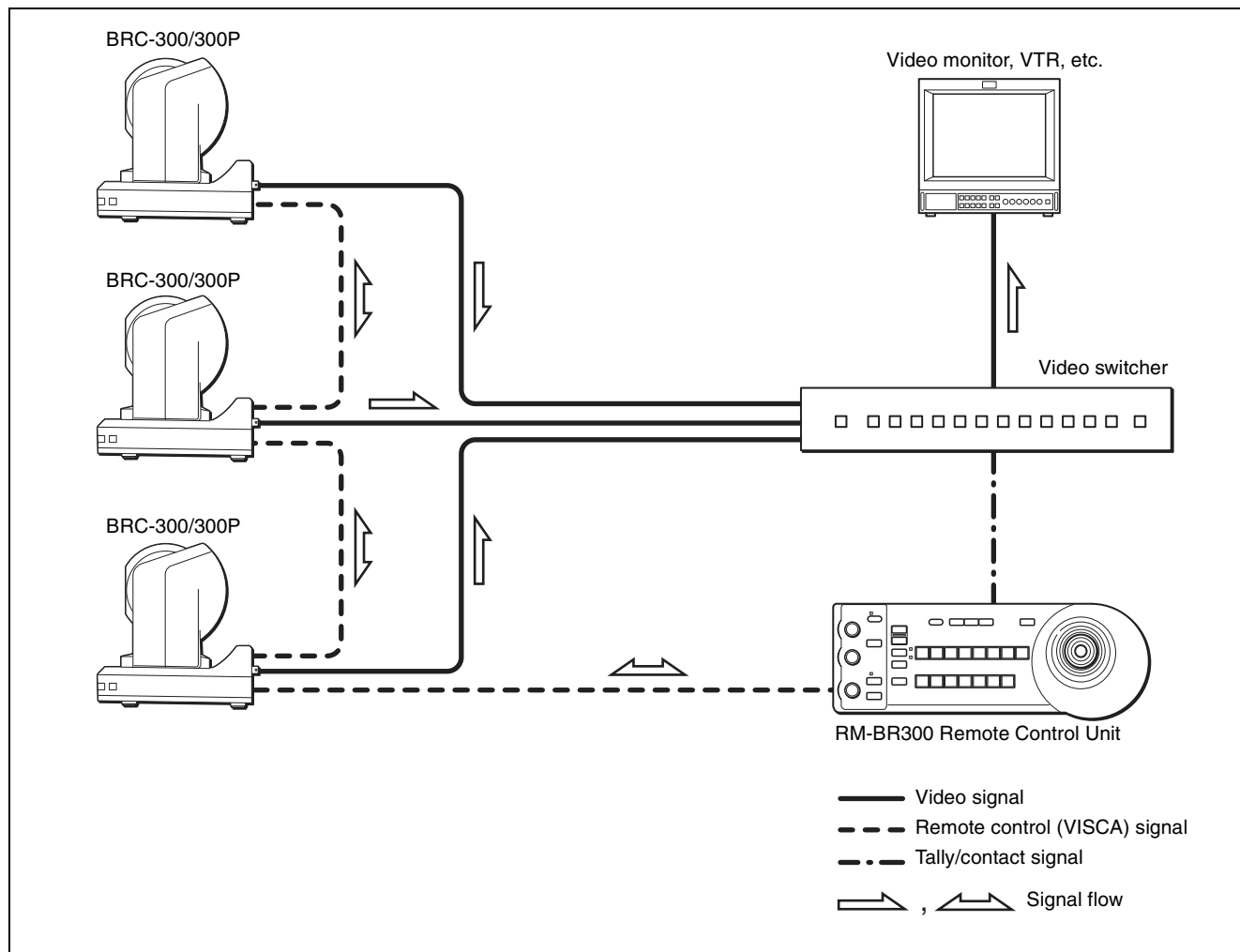

Operating a BRC-300/300P Camera from a Long Distance

This system allows you:

- To operate the camera remotely from a distance up to 500 m (1,640 feet)
- To perform pan/tilt and zoom operations comfortably using the joystick
- To transmit the video signal and control signal of the camera to a distant place using the Optical Fiber Cable

System configuration

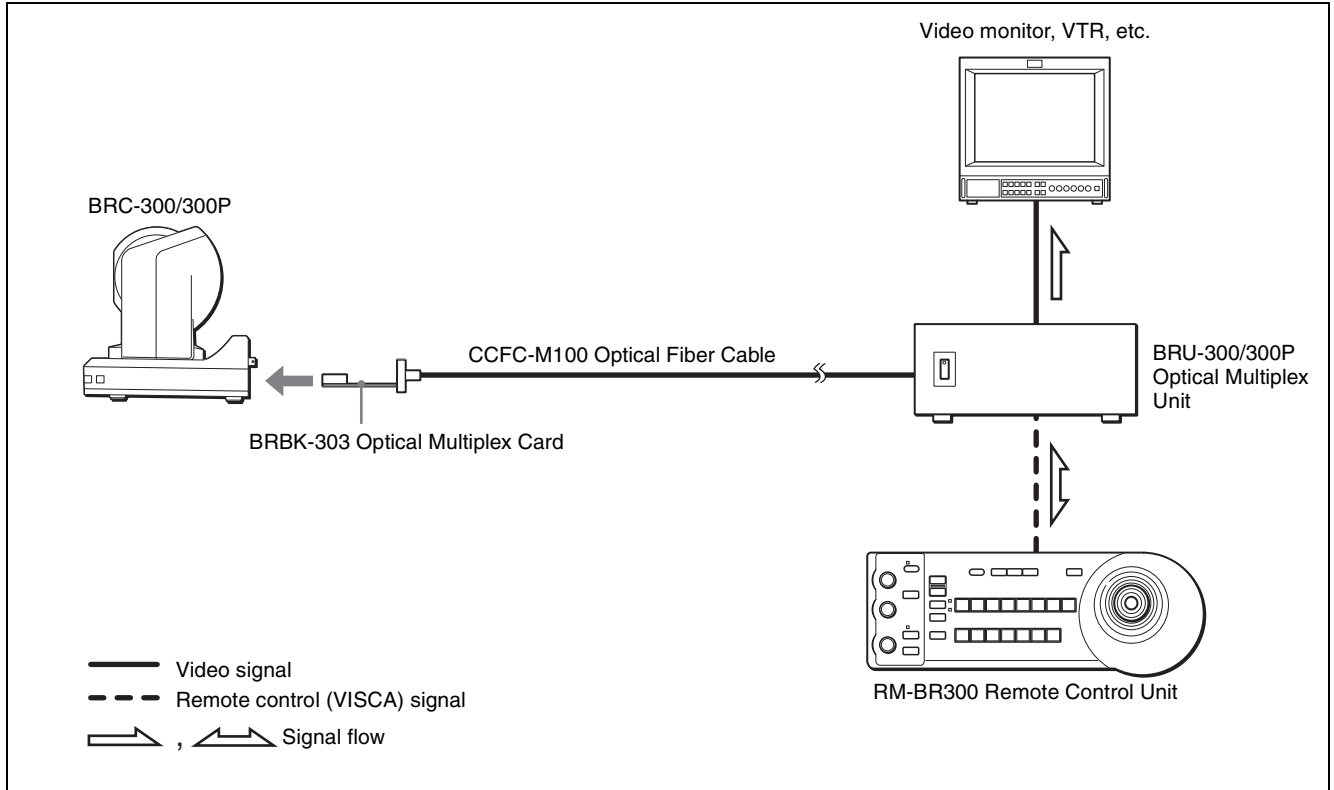

Notes

- The BRC-300/300P camera does not operate if nothing is connected to the BRBK-303 Optical Multiplex Card inserted into the camera. To operate the camera, connect the BRU-300/300P Optical Multiplex Unit to the BRBK-303 using the CCFC-M100 Optical Fiber Cable and turn on the power of the BRU-300/300P.
- When the BRBK-303 Optical Multiplex Card is inserted into the BRC-300/300P camera, the EXT SYNC connector, VISCA RS-232C IN/OUT connectors and VISCA RS-422 connector on the rear of the camera and the BOTTOM switches on the bottom of the camera are disabled. Use the connectors and switches on the rear of the BRU-300/300P Optical Multiplex Unit instead.

Operating Multiple BRC-300/300P Cameras from a Long Distance

This system allows you:

- To operate up to seven cameras remotely from a distance up to 500 m (1,640 feet)
- To perform pan/tilt and zoom operations comfortably using the joystick
- To transmit the video signal and control signal of the cameras to a distant place using the Optical Fiber Cable

System configuration

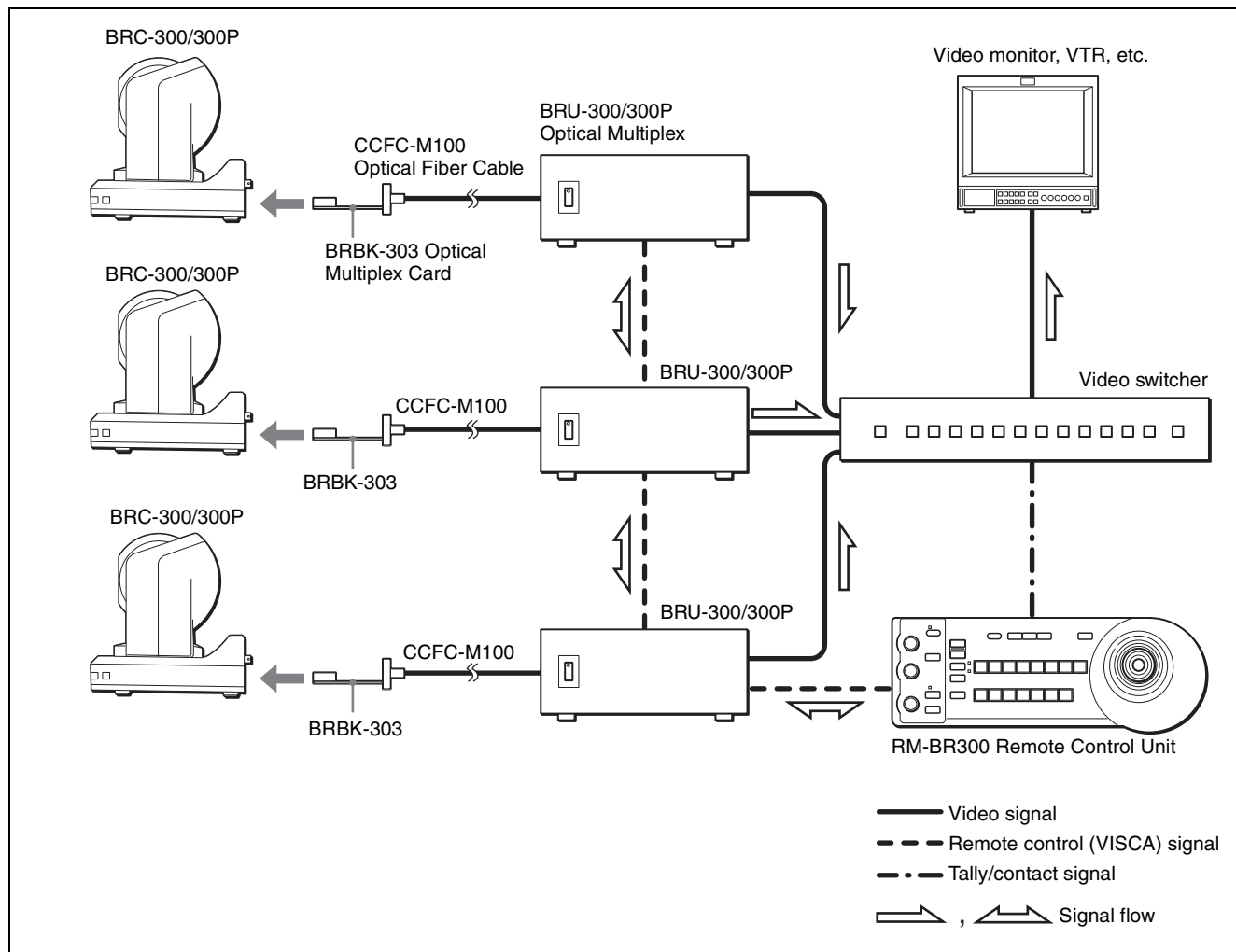

Using BRC-300/300P Cameras and VISCA-controllable Cameras in the Same System

This system allows you:

- To operate up to seven cameras supporting the VISCA protocol such as EVI-D30/D30P, EVI-D70/D70P and EVI-D100/D100P remotely using a single RM-BR300 Remote Control Unit
- To perform pan/tilt and zoom operations comfortably using the joystick
- To control the BRC-300/300P cameras remotely from a distance up to 500 m (1,640 feet) by transmitting the video signal and control signal using the Optical Fiber Cable

System configuration

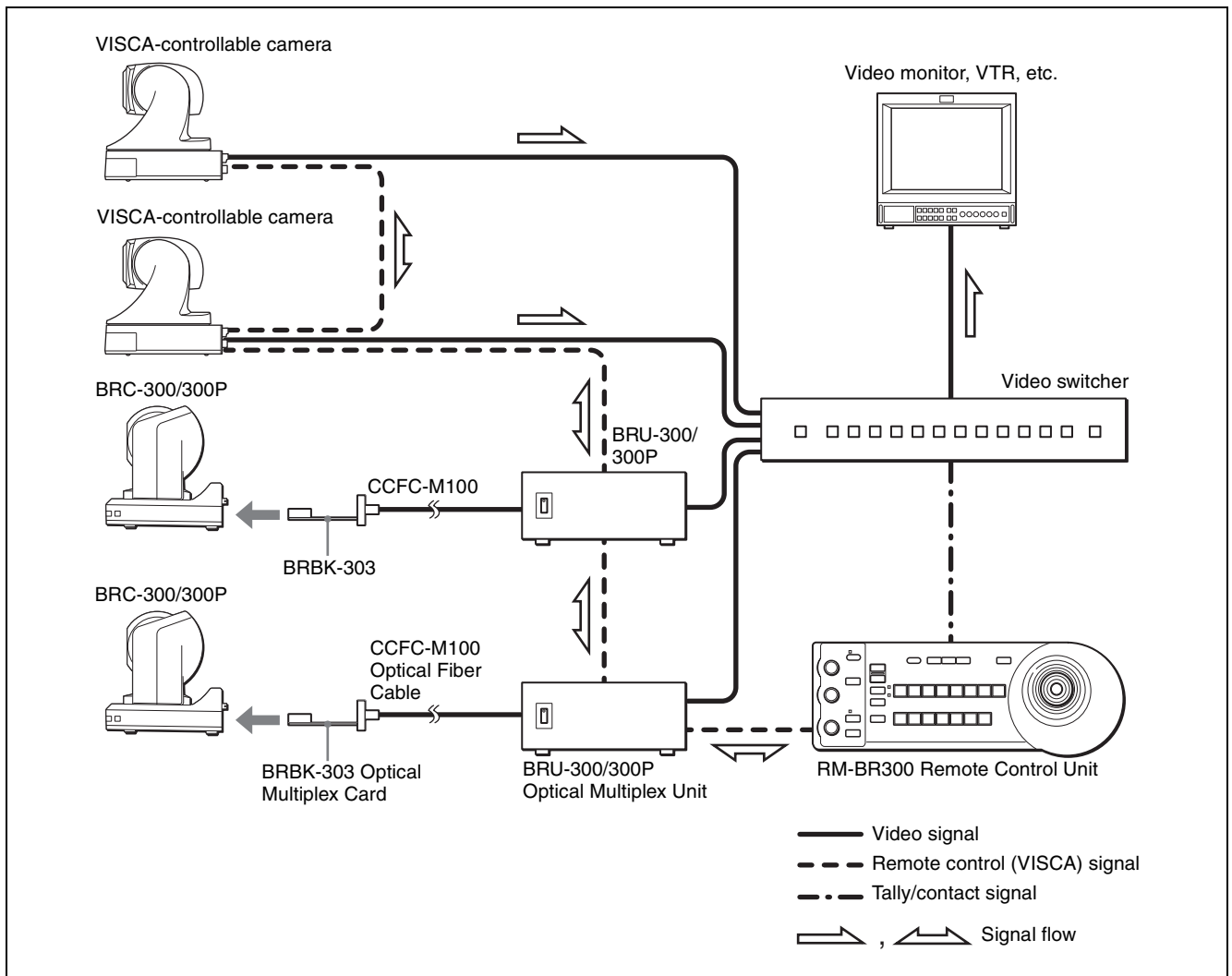

Location and Function of Parts

Camera

Front

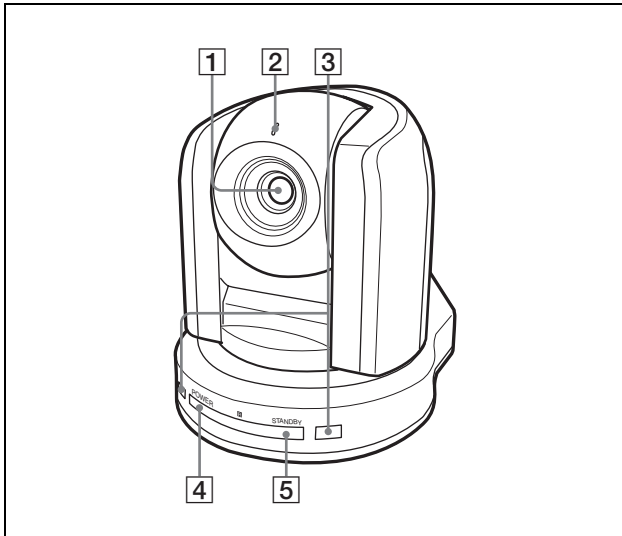

- 1 Lens**
A wide conversion lens (not supplied) can be attached.
- 2 Tally lamp**
Lights in red when a VISCA tally command is received or the camera is selected by the RM-BR300 Remote Control Unit (not supplied).
- 3 Remote sensor**
This is the sensor for the supplied Remote Commander.
- 4 POWER lamp**
Lights when the camera is connected to an AC outlet using the supplied AC power adaptor and AC power cord.
Flashes in green when the camera receives an operation command from the supplied Remote Commander.
- 5 STANDBY lamp**
Lights when the camera is turned off using the Remote Commander.

Rear

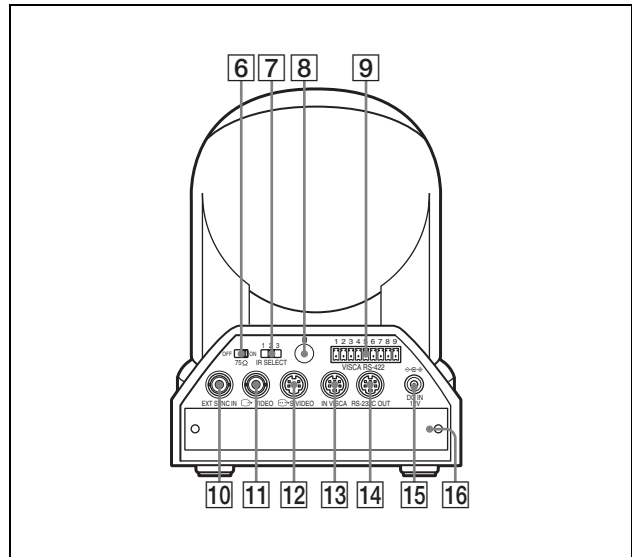

- 6 75-ohm termination switch**
This switch is used when an external sync signal is used. Set it to OFF when this camera is in the middle of a daisy chain connection of multiple cameras. Set it to ON when the camera is at the end of a daisy chain connection.
- 7 IR SELECT switch**
Select the camera number when you operate multiple cameras with the same Remote Commander.
- 8 Remote sensor**
This is the sensor for the supplied Remote Commander.
- 9 VISCA RS-422 connector**
Used for VISCA control.

For connection to the VISCA RS-422 connector, see "Using the VISCA RS-422 Connector Plug" on page 68.
- 10 EXT SYNC IN connector**
Accepts external video sync signals.
- 11 VIDEO connector**
Supplies the images as composite signals.
- 12 S VIDEO connector**
Supplies the images as Y/C separate (S video) signals.

- 13 VISCA RS-232C IN connector**
Connect to the RM-BR300 Remote Control Unit (not supplied). When you connect multiple cameras, connect it to the VISCA RS-232C OUT connector of the previous camera in the daisy chain connection.
- 14 VISCA RS-232C OUT connector**
When you connect multiple cameras, connect it to the VISCA RS-232C IN connector of the next camera in the daisy chain connection.
- 15 DC IN 12V connector**
Connect the supplied AC power adaptor.
- 16 Card slot**
Insert an optional interface card such as BRBK-301, BRBK-302 and BRBK-303. The slot cover is attached to the camera at the factory.

Bottom

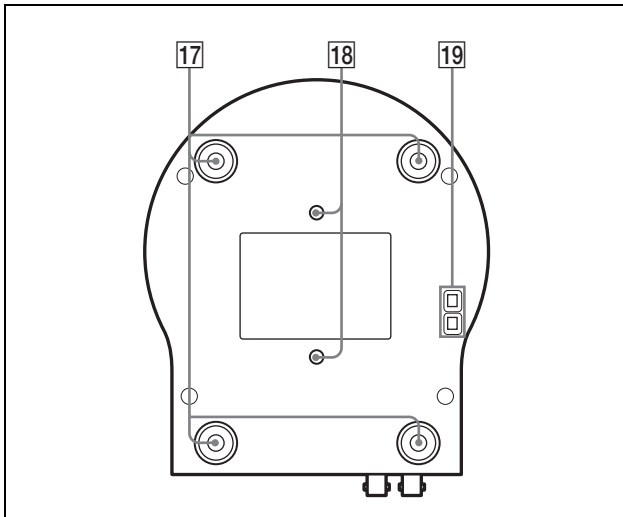

- 17 Ceiling bracket mounting screw holes**
When you install the camera to the ceiling, secure the supplied ceiling bracket to these holes using the supplied four screws.

For installation, see “Installing the Camera on the Ceiling” on page 43.
- 18 Tripod screw holes (1/4-20UNC)**
When you install the camera to a tripod, secure the tripod to these holes.
- 19 BOTTOM switches**
Used for the RS-232C/RS-422 selection, baud rate selection, remote control signal output on/off and camera address setting.

For details, see “Setting of the BOTTOM switches” on page 16.

Setting of the BOTTOM switches

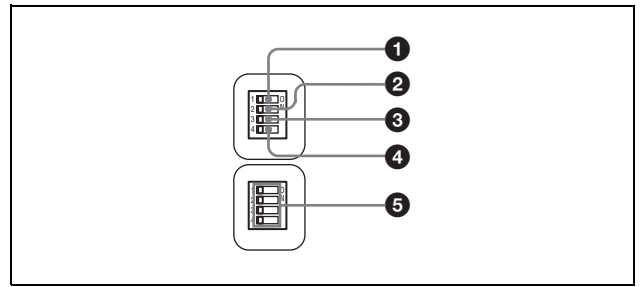

- 1 Switch 1 (No Connection)**
Always keep it OFF.
- 2 Switch 2 (RS-232C/RS-422 selector)**
Set to ON for RS-422, or OFF for RS-232C.
- 3 Switch 3 (Communication baud rate selector)**
Set to ON for 38400bps, or OFF for 9600bps.
- 4 Switch 4 (Infrared signal output switch)**
Set to ON to enable an infrared signal output, or OFF to disable the output.
- 5 Camera address selectors**
Set the address of the camera. Normally set to "0". With this setting, addresses are assigned to the cameras automatically in the connected order by pressing the POWER button while holding down the RESET button on the RM-BR300 Remote Control Unit. You can assign the camera address "1" to "7" manually by setting these selectors as follows:

Camera address	0	1	2	3	4	5	6	7
Switch 1	OFF	ON	OFF	ON	OFF	ON	OFF	ON
Switch 2	OFF	OFF	ON	ON	OFF	OFF	ON	ON
Switch 3	OFF	OFF	OFF	OFF	ON	ON	ON	ON

Note

Switch 4 is not used.

Remote Commander (supplied)

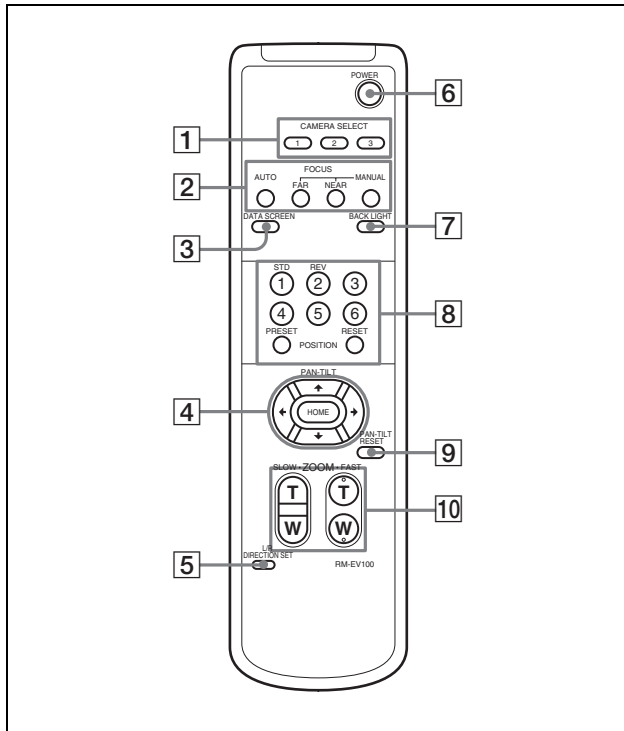

1 CAMERA SELECT buttons

Press the button corresponding to the camera you want to operate with the Remote Commander. The camera number can be set using the IR SELECT switch on the rear of the camera.

Note

If two or more cameras are adjacent and have the same camera number, they are operated simultaneously with the same Remote Commander. When you install the cameras close to each other, set different camera numbers.

For the camera number setting, see “Operating Multiple Cameras with the Remote Commander” on page 32.

2 FOCUS buttons

Used for focus adjustment. Press the AUTO button to adjust the focus automatically. To adjust the focus manually, press the MANUAL button, and adjust it with the FAR and NEAR buttons.

3 DATA SCREEN button

Press this button to display the main menu. Press it again to turn off the menu. If you press the button when a lower-level menu is selected, the display goes back to a higher-level menu.

Note

Pan/tilt and zoom operations are disabled when the menu is displayed.

4 PAN-TILT buttons

Press the arrow buttons to perform panning and tilting. Press the HOME button to face the camera back to the front.

5 L/R DIRECTION SET button

Hold down this button and press the REV button to change the direction of the camera movement opposite to that indicated by the arrow of the \leftarrow/\rightarrow buttons.

To reset the direction of the camera movement, press the STD button while holding down this button.

6 POWER switch

Press this button to turn on/off the camera when the camera is connected to an AC outlet.

7 BACK LIGHT button

Press this button to enable the backlight compensation. Press it again to disable the backlight compensation.

8 POSITION buttons

Hold down the PRESET button and press button 1 to 6 to store the current camera direction, zooming, focus adjustment and backlight compensation in the memory of the pressed number button. To erase the memory contents, hold down the RESET button and press button 1 to 6.

9 PAN-TILT RESET button

Press this button to reset the pan/tilt position.

10 ZOOM buttons

Use the SLOW button to zoom slowly, and the FAST button to zoom quickly. Press the T (telephoto) side of the button to zoom in, and the W (wide angle) side to zoom out.

Installing batteries

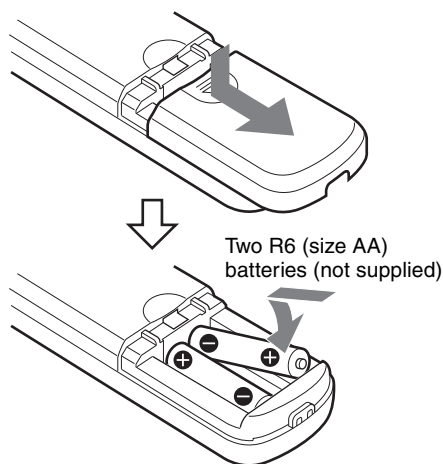

Caution

To avoid risk of explosion, use R6 (size AA) manganese or alkaline batteries.

RM-BR300 Remote Control Unit (not supplied)

This manual explains the operations of the RM-BR300 Remote Control Unit when it is used with BRC-300/300P cameras.

For operations with other cameras, refer to the Operating Instructions supplied with the RM-BR300.

Front

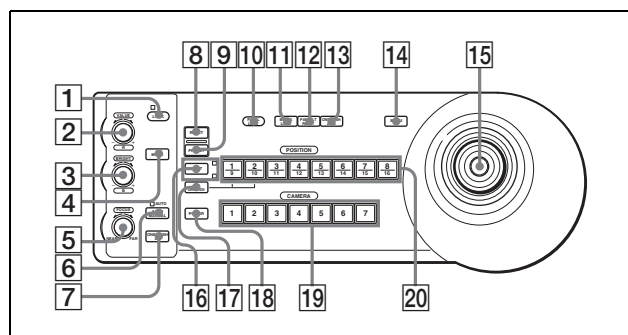

1 LOCK button and indicator

Press the LOCK button for more than one second, and the LOCK indicator lights and the values set by the VALUE/R, BRIGHT/B and FOCUS controls are locked. (The indicators of the locked controls are turned off.)

The AUTO/MANUAL button is also disabled. Press the LOCK button for more than one second again to unlock the controls and buttons.

2 VALUE/R control

When the brightness adjustment mode is selected with the MODE button (with the VALUE indicator lit), this control adjusts the value of the item (SHUTTER or IRIS) selected with the menu of the camera.

When the white balance adjustment mode is selected with the MODE button (with the R indicator lit), this control adjusts the R. GAIN (red gain).

When the VALUE indicator is lit, the function of the control varies according to the setting of the MODE button. For details, see “Functions of the VALUE and BRIGHT controls” on page 39.

3 BRIGHT/B control

When the brightness adjustment mode is selected with the MODE button (with the BRIGHT indicator lit), this control adjusts the value of the brightness of the camera, etc.

When the white balance adjustment mode is selected with the MODE button (with the B indicator lit), this control adjusts the B. GAIN (blue gain).

When the BRIGHT indicator is lit, the function of the control varies according to the setting of the MODE button. For details, see “Functions of the VALUE and BRIGHT controls” on page 39.

4 MODE button

Press this button to select the function of the VALUE/R control and BRIGHT/L control. When the brightness adjustment mode is selected, the VALUE and BRIGHT indicators are lit. When the white balance adjustment mode is selected, the R and B indicators are lit.

5 FOCUS control

Turn this control counterclockwise (toward NEAR) to focus on a near subject, and clockwise (toward FAR) to focus on a far subject.

6 AUTO/MANUAL button and AUTO indicator

Press this button to select focus mode AUTO or MANUAL. When AUTO is selected, the AUTO indicator lights and the FOCUS control and the ONE PUSH AF button are disabled.

When MANUAL is selected, the FOCUS control and the ONE PUSH AF button are enabled (with the FOCUS indicator lit).

7 ONE PUSH AF button

Press this button to perform the one-push auto focus function.

8 RESET button
 Hold down this button and press POSITION button 1 to 6, and the memory of the camera corresponding to the pressed POSITION button is cleared to the factory-preset conditions.

When multiple cameras are connected, hold down this button and press the POWER button to set the camera addresses.

9 PRESET button
 Hold down this button and press POSITION button 1 to 6, and the current camera settings are stored in the memory of the camera corresponding to the pressed POSITION button.

10 PANEL LIGHT button
 Press this button to illuminate all the POSITION buttons and CAMERA buttons. Press the button again to turn off the illumination.

11 BACK LIGHT button
 Press this button to enable the backlight compensation function of the camera. Press it again to disable the function.

12 PAN-TILT RESET button
 Press this button to reset the pan/tilt position of the camera to the initial conditions.

13 ONE PUSH AWB button
 When ONE PUSH is selected with the WHITE BALANCE menu of the camera, press this button to perform the one-push white balance adjustment.

14 MENU button
 Press this button to display or turn off the menu of the camera.

15 Joystick

When the menu of the camera is not displayed

The joystick is used for pan/tilt and zoom operations.
 When you incline the joystick right and left, the camera pans.
 When you incline it forward or backward, the camera tilts.
 The pan/tilt speed changes according to the angle of the inclination.
 When you release the joystick, the camera movement stops.
 When you turn the dial on the upper part of the joystick clockwise, the subject becomes larger (zoom in). When you turn it counterclockwise, the subject becomes smaller (zoom out).

When you press the button on the top of the joystick for one or two seconds with or without the menu displayed, the pan/tilt/zoom are reset and the camera returns to the front.

When the menu of the camera is displayed

The joystick is used for menu operations. Inclining the joystick right, left, forward and backward has the same function as pressing the arrow buttons of the supplied Remote Commander. Pressing the button on the top of the joystick has the same function as pressing the HOME button on the Remote Commander.

16 SHIFT button and indicators
 Press this button to select the function of the POSITION buttons for positions 1 to 8 or positions 9 to 16.

The upper indicator lights for positions 1 to 8, and the lower indicator for positions 9 to 16.

17 L/R DIRECTION button
 Hold down this button and press POSITION button 2 (REV) to reverse the pan direction to the direction in which you incline the joystick. To reset the direction, hold down this button and press POSITION button 1 (STD).

18 POWER button
 Press this button to light the CAMERA button(s) corresponding to the status of the connected camera(s).

Blue: The power of the camera is on.

Yellow green: The camera is in standby mode.

Off: No camera is connected.

Hold down this button and press CAMERA button 1 to 7 to turn on/off the power of the camera corresponding to the pressed button.

19 CAMERA buttons
 Press one of the buttons to select the camera from among those connected. The selected CAMERA button lights in blue.

20 POSITION buttons
 You can store the various camera settings such as the pan, tilt and zoom positions to the memory of the camera corresponding to each POSITION button, and load the settings in the memory.

Rear/Bottom

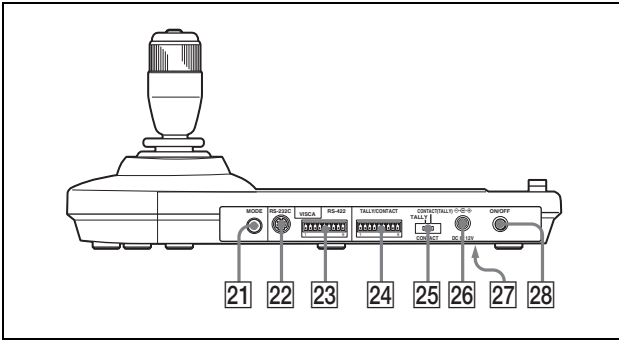

21 MODE selector

Select the position corresponding to the VISCA-controllable camera to be connected.

Switch position	Camera mode
0	Automatically selected (default)
1	BRC-300/300P
2	EVI-D70/D70P
3	EVI-D100/D100P
4	EVI-D30/D30P

Note

Use position 1 to 4 when all the connected cameras are of the same model.

22 VISCA RS-232C connector

Connect to the VISCA RS-232C IN connector of the camera or the BRU-300/300P Optical Multiplex Unit.

23 VISCA RS-422 connector

Connect to the VISCA RS-422 connector of the camera or the BRU-300/300P Optical Multiplex Unit.

An RS-422 connector plug is attached at the factory.

24 TALLY/CONTACT connector

This connector is used for the tally lamp input or the contact output.

Select the function of the connector using the TALLY/CONTACT selector.

An RS-422 connector plug is attached at the factory.

25 TALLY/CONTACT selector

Select the function of the TALLY/CONTACT connector.

TALLY: The tally lamp of the camera selected with the connected switcher lights.

CONTACT: The contact output corresponding to the camera address selected with the Remote Control Unit is short-circuited against the connected switcher.

CONTACT (TALLY): The contact output corresponding to the camera address selected with the Remote Control Unit is short-circuited against the connected switcher and the tally lamp of the camera selected with the connected switcher lights.

Note

Change the setting of the selector before you turn on the power of the Remote Control Unit. Otherwise, the setting is not effective.

26 DC IN 12V connector

Connect the supplied AC power adaptor.

27 DIP switches (bottom)

Switch 1 (RS-232C/RS-422 selector)

Set to ON for RS-422, or OFF for RS-232C.

Switch 2 (Communication baud rate selector)

Set to ON for 38400bps, or OFF for 9600bps.

Note

Set the DIP switches before you turn on the power of the Remote Control Unit. Otherwise, the setting is not effective.

28 ON/OFF switch

Press this switch to turn on/off the Remote Control Unit.

BRU-300/300P Optical Multiplex Unit (not supplied)

Front

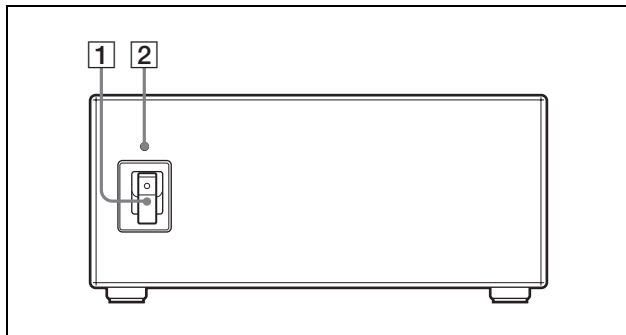

- 1 Power switch**
Turns on/off the power of the Optical Multiplex Unit.
- 2 Power indicator**
Lit in green: The Optical Multiplex Unit is in normal operation.
Lit in red: The power of the camera is turned off. Turn it on.
Flashing in red: Abnormal operation of the Optical Multiplex Unit. Display the composite video signal on the monitor and check the error message. Check also the connection.

For the error message, see “List of Messages” on page 54.

Rear

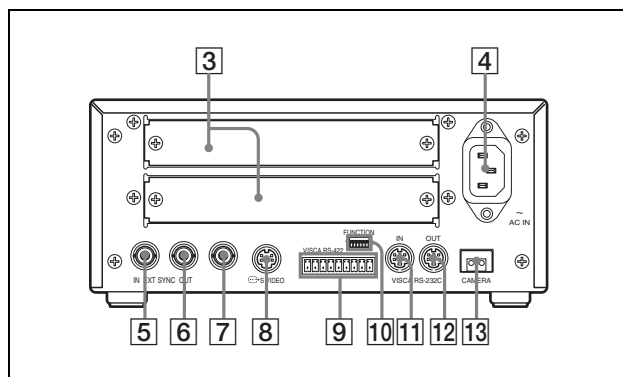

- 3 Card slot**
Insert an optional interface card such as BRBK-301 or BRBK-302.
The slot cover is attached to the camera at the factory.
- 4 AC IN connector**
Connect the supplied AC power cord.
- 5 EXT SYNC IN connector**
Accepts external video sync signals.
- 6 EXT SYNC OUT connector**
Supplies external video sync signals.
- 7 Composite video output connector**
Supplies the images from the camera as composite signals.
- 8 S VIDEO connector**
Supplies the images from the camera as Y/C separate (S video) signals.
- 9 VISCA RS-422 connector**
Connect to the VISCA RS-422 connector of the camera or another BRU-300/300P Optical Multiplex Unit.

For the connection to the VISCA RS-422 connector, see “Using the VISCA RS-422 Connector Plug” on page 68.
- 10 VISCA FUNCTION switches**
These switches are used for the VISCA communication settings.

Switch 1 (RS-232C/RS-422 selector)
Set to ON for RS-422, or OFF for RS-232C.

Switch 2 (Communication baud rate selector)
Set to ON for 38400bps, or OFF for 9600bps.

Switches 3 to 5 (Camera address selectors)

Set the address of the camera.

Normally set to "0". With this setting, addresses are assigned to the cameras automatically in the connected order by pressing the POWER button while holding down the RESET button on the RM-BR300 Remote Control Unit.

You can assign the camera address "1" to "7" manually by setting these selectors as follows:

Camera address	0	1	2	3	4	5	6	7
Switch 3	OFF	ON	OFF	ON	OFF	ON	OFF	ON
Switch 4	OFF	OFF	ON	ON	OFF	OFF	ON	ON
Switch 5	OFF	OFF	OFF	OFF	ON	ON	ON	ON

Note

Switch 6 is not used.

- 11 VISCA RS-232C IN connector**
Connect to the RM-BR300 Remote Control Unit (not supplied). When you connect multiple cameras, connect it to the VISCA RS-232C OUT connector of the previous camera in the daisy chain connection.
- 12 VISCA RS-232C OUT connector**
When you connect multiple cameras, connect it to the VISCA RS-232C IN connector of the next camera in the daisy chain connection.
- 13 CAMERA connector**
Connect to the optical connector of the BRBK-303 Optical Multiplex Card installed in the BRC-300/300P camera using the CCFC-M100 Optical Fiber Cable.
A dustproof cap is attached at the factory.

BRBK-301 Analog RGB Component Card (not supplied)

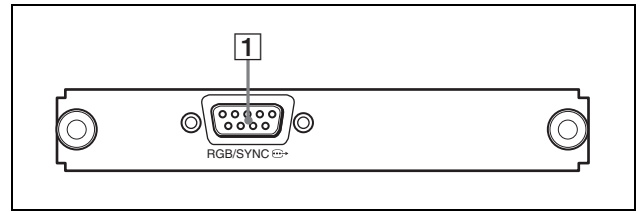

- 1 RGB/SYNC connector**
Supplies various analog signals such as composite video, S video, component video and RGB signals. The output signal can be selected with the ANALOG OUT menu of the camera.

BRBK-302 SDI Card (not supplied)

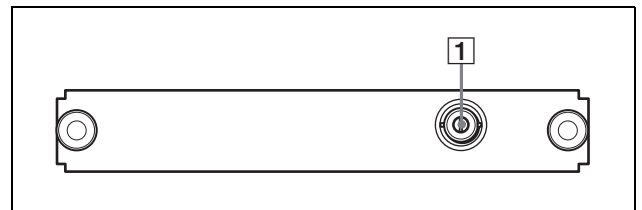

- 1 SDI connector**
Supplies a signal conforming to SMPTE259M serial digital interface standards.

BRBK-303 Optical Multiplex Card (not supplied)

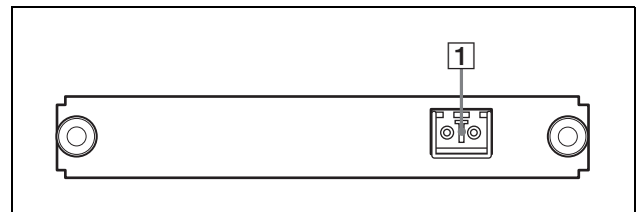

- 1 Optical connector**
Performs the optical digital multiplex transmission of video, external sync and control signals. A dustproof cap is attached at the factory.

About On-Screen Menus

You can change various settings, such as shooting conditions and system setup of the camera, while observing menus displayed on a connected monitor. This section explains how to read the on-screen menus before starting menu operations.

For the overall menu configurations, see page 57.

Note

You cannot perform pan/tilt and zoom operations while the menu is displayed.

Main Menu

To display the main menu, press the DATA SCREEN button on the supplied Remote Commander or the MENU button on the RM-BR300 Remote Control Unit.

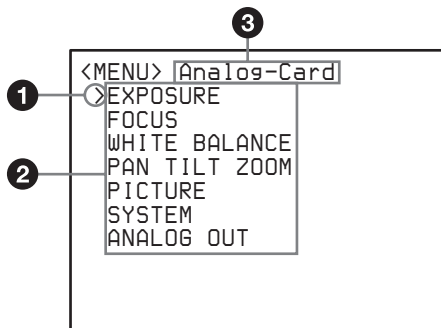

- 1 Cursor**
Selects a setting menu.
Move the cursor up or down pressing the \uparrow or \downarrow button on the Remote Commander or inclining the joystick of the RM-BR300 Remote Control Unit forward or backward.
- 2 Menu items**
To display a setting menu, select one using the \uparrow or \downarrow button on the Remote Commander or the joystick of the RM-BR300 Remote Control Unit, and press the HOME button on the Remote Commander or the top button of the joystick on the RM-BR300.
- 3 Option card indicator**
Displays the name of the interface card inserted into the card slot of the camera.
(The illustration above shows an example when the BRBK-301 Analog RGB Component Card is inserted.)

Setting Menu

The setting menu selected on the main menu is displayed.

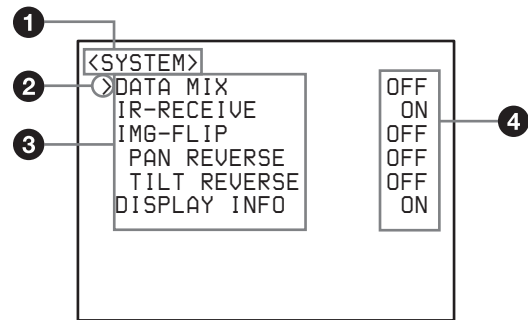

- 1 Setting menu**
The name of the setting menu currently selected is displayed here.
- 2 Cursor**
Selects a setting item.
Move the cursor up or down pressing the \uparrow or \downarrow button on the Remote Commander or inclining the joystick of the RM-BR300 Remote Control Unit forward or backward.
- 3 Setting items**
The setting items for this setting menu are displayed.
To change a set value, select the setting item using the \uparrow or \downarrow button on the Remote Commander or the joystick of the RM-BR300 Remote Control Unit, and press the \leftarrow or \rightarrow button on the Remote Commander or incline the joystick on the RM-BR300 right or left.
- 4 Set value**
The currently set values are displayed.
To change a set value, use the \leftarrow or \rightarrow button on the Remote Commander or the joystick of the RM-BR300 Remote Control Unit.

For the default value of each setting item, see “Menu Configuration” on page 57.

Operation Through Menus

This section explains how to operate the menu using the supplied Remote Commander, or using the RM-BR300 Remote Control Unit (not supplied).

For details on each menu, see pages 27 through 30.

Menu Operation Using the Supplied Remote Commander

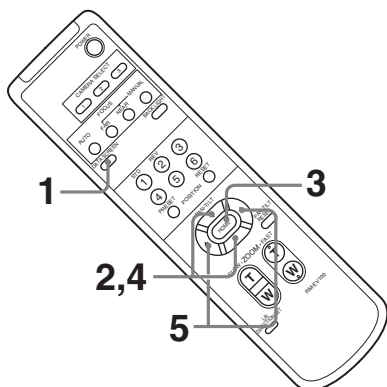

- 1 Press the DATA SCREEN button.
The main menu appears.

```
<MENU> Analog-Card
>EXPOSURE
FOCUS
WHITE BALANCE
PAN TILT ZOOM
PICTURE
SYSTEM
ANALOG OUT
```

- 2 Move the cursor to the menu item to be set by pressing the \uparrow or \downarrow button.

- 3 Press the HOME button.
The selected menu appears.

```
<SYSTEM>
>DATA MIX           OFF
IR-RECEIVE         ON
IMG-FLIP           OFF
PAN REVERSE        OFF
TILT REVERSE       OFF
DISPALY INFO       ON
```

- 4 Move the cursor to the setting item to be changed by pressing the \uparrow or \downarrow button.
- 5 Change the value by pressing the \leftarrow or \rightarrow button.

```
<SYSTEM>
>DATA MIX           ON
IR-RECEIVE         ON
IMG-FLIP           OFF
PAN REVERSE        OFF
TILT REVERSE       OFF
DISPLAY INFO       ON
```

Note

When you are operating the menu using the supplied Remote Commander, you cannot set IR-RECEIVE in the SYSTEM menu to OFF. To set IR-RECEIVE to OFF, use the RM-BR300 Remote Control Unit or the VISCA command.

To return to the main menu

Press the DATA SCREEN button.

To return to the normal display

Pres the DATA SCREEN button when the main menu is displayed.

Menu Operation Using the RM-BR300 Remote Control Unit

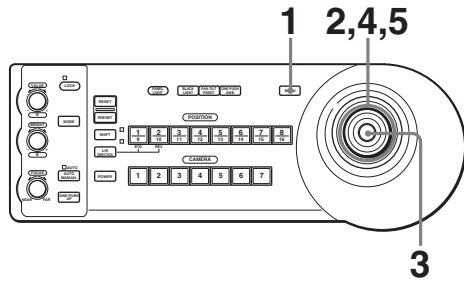

- 1 Press the MAIN button.
The main menu appears.

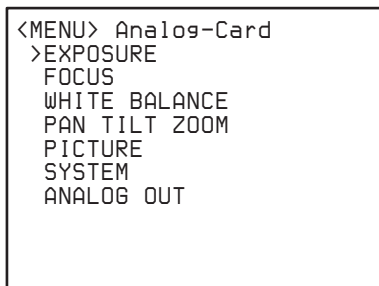

- 2 Move the cursor to the menu item to be set by inclining the joystick forward or backward.
- 3 Press the button on the top of the joystick.
The selected menu appears.

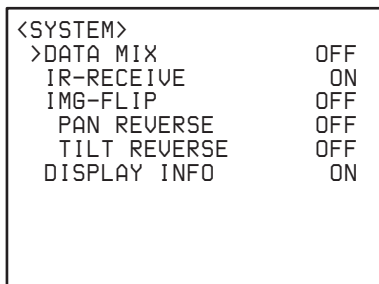

- 4 Move the cursor to the setting item to be changed by inclining the joystick forward or backward.

- 5 Change the value by inclining the joystick right or left.

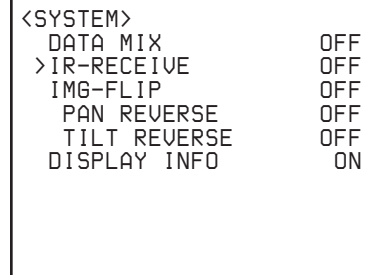

To return to the main menu

Press the MENU button.

To return to the normal display

Press the MENU button when the main menu is displayed.

EXPOSURE Menu

The EXPOSURE menu is used to set the items regarding the exposure.

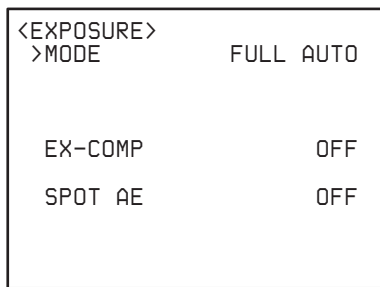

MODE (exposure mode)

FULL AUTO: The exposure is adjusted automatically using the sensitivity, electronic shutter speed and iris.

MANUAL: Adjust the gain (GAIN), electronic shutter speed (SPEED) and iris (IRIS) manually.

SHUTTER Pri: Shutter Priority mode. The exposure is adjusted automatically using the sensitivity and iris. Adjust the electronic shutter speed (SPEED) manually.

IRIS Pri: Iris Priority mode. The exposure is adjusted automatically using the sensitivity and electronic shutter speed. Adjust the iris (IRIS) manually.

BRIGHT: Adjust the brightness level (LEVEL) manually.

When you select MODE, some of the following setting items that are required for the selected mode appear.

GAIN: Select the gain from among the following:
-3, 0, 3, 6, 9, 12, 15, 18 dB

SPEED: Select the electronic shutter speed from among the following:
For the BRC-300:
1/4, 1/8, 1/15, 1/30, 1/60, 1/90, 1/100, 1/125, 1/180, 1/250, 1/350, 1/500, 1/725, 1/1000, 1/1500, 1/2000, 1/3000, 1/4000, 1/6000, 1/10000 sec.

For the BRC-300P:
1/3, 1/6, 1/12, 1/25, 1/50, 1/75, 1/100, 1/120, 1/150, 1/215, 1/300, 1/425, 1/600, 1/1000, 1/1250, 1/1750, 1/2500, 1/3500, 1/6000, 1/10000 sec.

IRIS: Select the iris from among the following:
CLOSE, F28, F22, F19, F16, F14, F11, F9.6, F8, F6.8, F5.6, F4.8, F4, F3.4, F2.8, F2.4, F2.0, F1.6

LEVEL: Select the brightness level from among 0 to 23.

EX-COMP (exposure compensation)

When MODE is set to FULL AUTO, SHUTTER Pri or IRIS Pri, set to ON to enable the exposure compensation.

When you set EX-COMP to ON, LEVEL appears and you can select the exposure compensation level from among the following:

-10.5, -9, -7.5, -6, -4.5, -3, -1.5, 0, 1.5, 3, 4.5, 6, 7.5, 9, 10.5 dB

SPOT AE (automatic exposure by spot)

When SPOT AE is set to ON, the automatic exposure adjustment is performed by detecting the luminance level of the selected spot in a 256-divided screen. This is suitable when you shoot a very small object.

When you set SPOT AE to ON, H-POS (horizontal position) and V-POS (vertical position) appear and you can select the spot position to detect the luminance level from among the following values:

H-POS: LEFT END, LEFT7, LEFT6, LEFT5, LEFT4, LEFT3, LEFT2, LEFT1, CENTER, RIGHT1, RIGHT2, RIGHT3, RIGHT4, RIGHT5, RIGHT6, RIGHT END

V-POS: DOWN END, DOWN6, DOWN5, DOWN4, DOWN3, DOWN2, DOWN1, CENTER, UP1, UP2, UP3, UP4, UP5, UP6, UP7, UP END

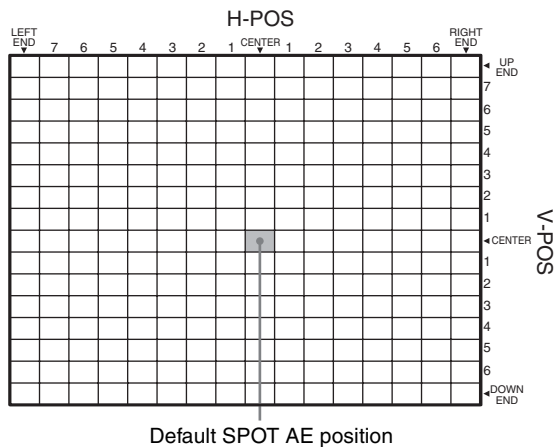

FOCUS Menu

The FOCUS menu is used to select the focus mode.

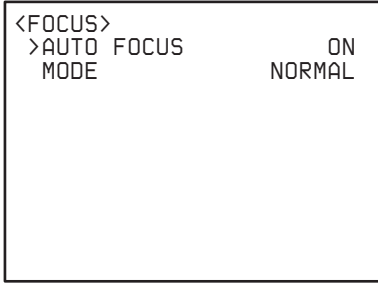

AUTO FOCUS (automatic focus)

Set to ON to perform the automatic focus adjustment. When it is set to ON, MODE appears and you can select the automatic focus adjustment mode from among the following:

NORMAL: The automatic focus adjustment is always activated.

INTERVAL: The automatic focus adjustment is activated only during the selected activation period of time (ACT-TIME) with the selected interval (INT-TIME).

ZOOM Trig: The automatic focus adjustment is activated after zooming operation is finished, only during the selected activation period of time (ACT-TIME).

When you select MODE, ACT-TIME and/or INT-TIME that are required for the selected mode appear.

ACT-TIME: Select the period of time for which the automatic focus adjustment is activated from 000 to 255 secs.

INT-TIME: Select the interval with which the automatic focus adjustment is activated from 000 to 255 secs.

WHITE BALANCE Menu

The WHITE BALANCE menu is used to select the white balance mode.

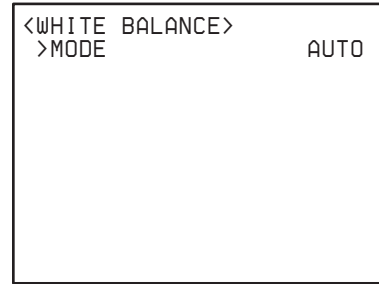

MODE (white balance mode)

Select the white balance mode from among the following:
AUTO, INDOOR, OUTDOOR, ONE PUSH, MANUAL

When you select MANUAL, R.GAIN (red gain) and B.GAIN (blue gain) appear. You can select each item from 0 to 255.

When ONE PUSH is selected

Zoom in on a white subject in the center of the screen and press the HOME button of the supplied Remote Commander. The one-push white balance adjustment is activated.

PAN TILT ZOOM Menu

The PAN TILT ZOOM menu is used to select the pan/tilt/zoom mode.

<PAN TILT ZOOM>		
>PAN-TILT LIMIT		
PAN		ON
LEFT		END
RIGHT		END
TILT		ON
DOWN		END
UP		END
D-ZOOM		ON
LIMIT		×4

PAN-TILT LIMIT

When you set PAN to ON, LEFT and RIGHT appear and you can select the limit of pan operation. When you set TILT to ON, UP and DOWN appear and you can select the limit of tilt operation.

You can select the following values:

PAN LEFT: LEFT END, +35359 to -35241 STEP, selectable with an interval of 200 STEP

PAN RIGHT: RIGHT END, -35241 to +35359 STEP, selectable with an interval of 200 STEP

TILT DOWN: DOWN END, -06170 to +18630 STEP, selectable with an interval of 200 STEP

TILT UP: UP END, +18630 to -06170 STEP, selectable with an interval of 200 STEP

1 STEP represents 0.0048°.

Setting range of PAN LEFT/PAN RIGHT

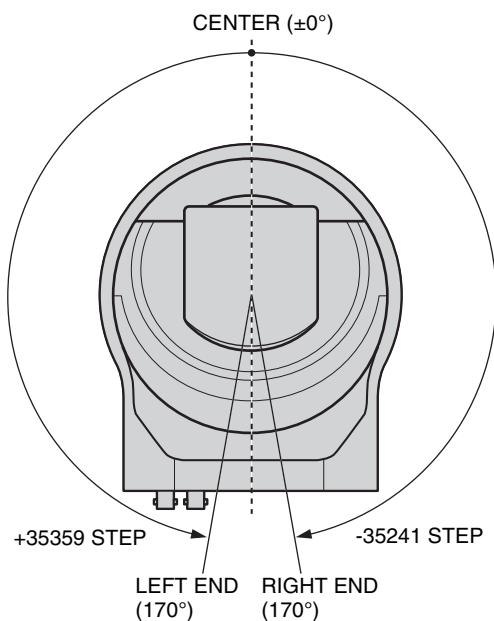

Setting range of TILT DOWN/TILT UP

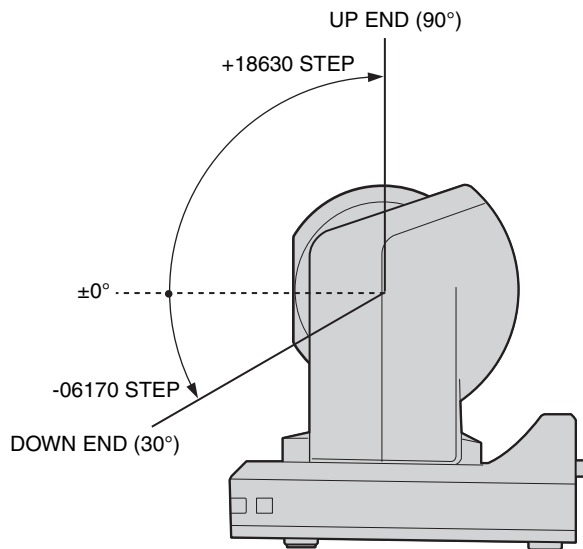

Note

The PAN-TILT LIMIT setting is reset to the factory setting when you change IM-FLIP of the SYSTEM menu.

D-ZOOM (digital zoom)

When it is set to ON, LIMIT appears and the electronic zoom (×4 or ×2) operates after the optical zoom (×12), giving ×48 zooming at maximum.

Select the magnification of the electronic zoom ×4 or ×2 by LIMIT.

Note

Regardless of the D-ZOOM ON/OFF setting, images shot by the camera are accumulated for the vertical synchronization period and output from the VIDEO and S VIDEO connectors of the camera and the connector on the optional interface card inserted into the card slot.

PICTURE Menu

<PICTURE>	
>EFFECT	OFF
WIDE	OFF
APERTURE	08

EFFECT (picture effect)

OFF: No picture effect

NEG: The image of the camera is reversed to negative.

B&W: The image of the camera becomes monochrome.

WIDE (wide mode)

ON: 16:9 aspect ratio of the image of the camera

OFF: 4:3 aspect ratio of the image of the camera

APERTURE (aperture compensation)

Select the aperture compensation level from among MIN, 01 to 14 and MAX.

SYSTEM Menu

<SYSTEM>	
>DATA MIX	OFF
IR-RECEIVE	ON
IMG-FLIP	OFF
PAN REVERSE	OFF
TILT REVERSE	OFF
DISPLAY INFO	ON

DATA MIX

When it is set to ON, the menu is overlapped with the video signal output from the installed interface card.

IR-RECEIVE (infrared signal reception)

When it is set to OFF, the camera does not receive the signal from the supplied Remote Commander.

Be sure to keep it ON when you use the supplied Remote Commander.

Note

You cannot set IR-RECEIVE to OFF when you operate the menu using the supplied Remote Commander. To set it to OFF, use the RM-BR300 Remote Control Unit (not supplied) or the VISCA command.

IMG-FLIP (image flip)

Set IMG-FLIP to ON to rotate the camera image supplied from the VIDEO connector upside down and to reverse the direction of the camera movement by pan/tilt operations.

Set PAN REVERSE to ON to reverse the horizontal movement of the camera image.

Set TILT REVERSE to ON to reverse the vertical movement of the camera image.

When you set IMG-FLIP to ON, "Please restart system" appears. Turn off the power of the camera and turn it on again.

Note

Regardless of the IMG-FLIP ON/OFF setting, images shot by the camera are accumulated for the vertical synchronization period and output from the VIDEO and S VIDEO connectors of the camera and the connector on the optional interface card inserted into the card slot.

DISPLAY INFO

When the camera settings are stored in POSITION 1 to 6 using the supplied Remote Commander (page 34), the message "PRESET No. xx" automatically appears for 2 seconds on the monitor screen. If you want to display the message each time the camera is operated, set DISPLAY INFO to ON. Set it to OFF to cancel the display.

ANALOG OUT Menu

The ANALOG OUT menu appears only when the BRBK-301 Analog RGB Component card is installed in the card slot of the camera.

```
<ANALOG OUT>
>OUTPUT 1      RGB
  SYNC         G
  OUTPUT 2     VBS
```

OUTPUT 1

Select the signal output from pins 3, 4 and 5 of the 9-pin D-sub connector of the Analog RGB Component Card. Set to RGB for the RGB signal output, or YCrCb for the component signal output.

When RGB is selected, SYNC appears, and you can select the sync signal from among G, RGB, and OFF.

OUTPUT 2

Select the signal output from pin 6 of the 9-pin D-sub connector of the Analog RGB Component Card. Set to VBS for the composite signal output, or Y/C for the S video signal output.

Operation Using the Supplied Remote Commander

Before operating, check that the camera and peripheral devices are properly installed and connected.

For details, see “Installation” (page 42) and “Connections” (page 46).

Turning on the Power

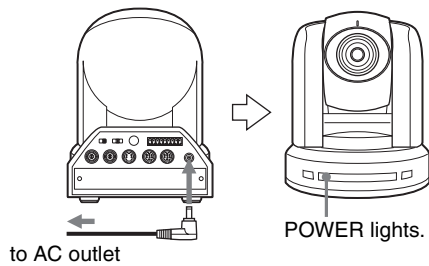

- 1 Connect the camera to an AC outlet using the supplied AC power adaptor and power cord. The power is turned on and the POWER lamp lights. The camera will automatically pan and tilt and be reset to the position stored in POSITION 1 (Pan/tilt reset action).

- 2 Turn on the peripheral devices.

To turn on/off the camera using the Remote Commander

As long as the camera is connected to an AC outlet, you can turn the camera on or off with the POWER switch on the Remote Commander.

When you turn the power off using the Remote Commander, the POWER lamp turns off and the STANDBY lamp lights on the camera.

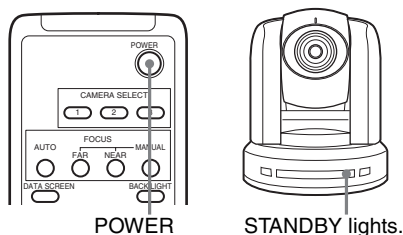

Pan/Tilt and Zoom Operation

Panning and Tilting

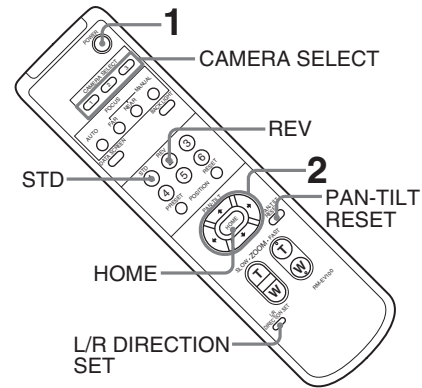

- 1 Press the POWER switch. The camera will turn on and perform the pan/tilt reset action automatically.
- 2 Press the arrow button to pan or tilt the camera. While checking the picture on the screen, press the desired arrow button.
 - To move the camera little by little**, press the button just for a moment.
 - To move the camera in a wide range**, press and hold the button.
 - To move the camera diagonally**, press the \uparrow or \downarrow button while holding down the \leftarrow or \rightarrow button.

To face the camera back to the front



Press the HOME button.

If you accidentally move the camera with your hand

Press the PAN-TILT RESET button to perform the pan/tilt reset action.

If the camera moves in a different direction from that you intended

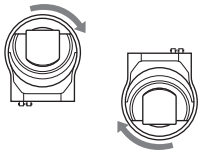
The camera is preset to face toward the right whenever the \rightarrow button is pressed. You might wish to face the camera toward the opposite direction from that of the button you pressed, for example, when you change the direction of the camera while checking the picture on the screen. In such a case, press the 2 (REV) button while holding down the L/R DIRECTION SET button. To reset the setting, press the 1 (STD) button while holding down the L/R DIRECTION SET button.

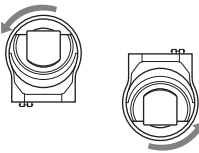
Arrow button	Movement of the camera	Setting
		L/R DIRECTION SET While holding down STD 1 Press.
		L/R DIRECTION SET While holding down REV 2 Press.

Note

The setting above only changes the signal emitted from the Remote Commander, and does not change the setting of the camera itself. Therefore, repeat the setting for each Remote Commander if you are using more than one Remote Commander.

If the STANDBY lamp of the camera flashes

When the camera is moved or turned by hand or by external shock, the microcomputer inside the camera may not be able to memorize the pan/tilt position properly and the camera may stop. To reset the pan/tilt position, press the PAN-TILT RESET button or turn the power of the camera off and turn it on again.

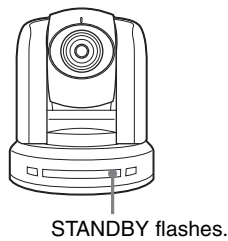

Zooming

Press either of the ZOOM buttons.

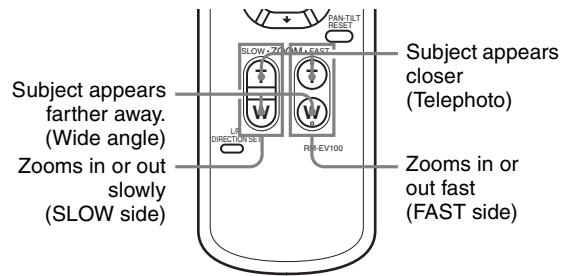

Note

When you perform pan/tilt operation while the camera is in the telephoto mode, the moving speed of the image on the screen may be a little jerky.

Operating Multiple Cameras with the Remote Commander

- 1 Set the IR SELECT switch on the rear of the camera you want to operate to 1, 2 or 3.



- 2 Press the CAMERA SELECT button on the Remote Commander that corresponds to the number set in step 1.

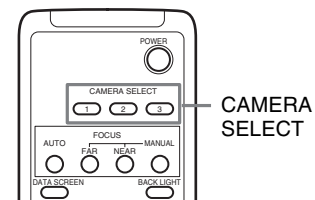

Then, you can operate the camera(s) specified by number. Every time you operate the camera(s) using the Remote Commander, the CAMERA SELECT button pressed in step 2 lights.

Adjusting the Camera

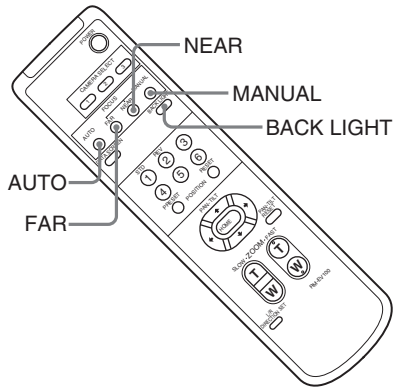

Shooting with Back Lighting

When you shoot a subject with a light source behind it, the subject becomes dark. In such a case, press the BACK LIGHT button.

To cancel the function, press the BACK LIGHT button again.

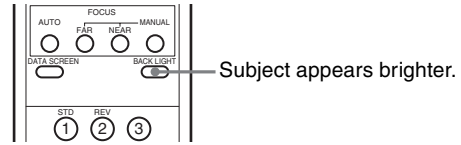

Note

The BACK LIGHT function is effective only when MODE is set to FULL AUTO in the EXPOSURE menu of the camera.

Focusing on a Subject

To focus the camera on a subject automatically

Press the AUTO button.

The camera focuses on the subject at the center of the screen automatically.

To focus the camera on a subject manually

After pressing the MANUAL button, press either the FAR or the NEAR button to have the camera focus on the subject.

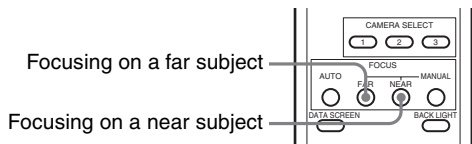

Storing the Camera Settings in Memory

– Presetting Feature

Up to six combinations of settings (six positions) including camera position, zooming, focusing, and backlighting, can be preset.

For details of the camera settings to be preset, see “Presetting Items” on page 59.

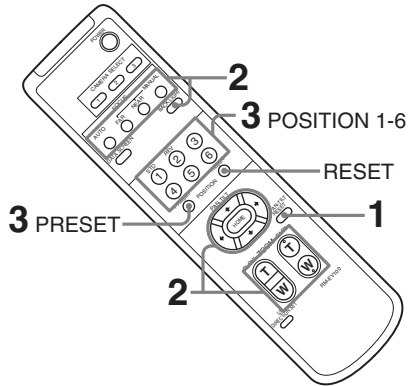

- 1 Press the PAN-TILT RESET button to reset the pan/tilt position.
- 2 Adjust the position, zooming, focusing and backlighting of the camera (pages 31 to 33).
- 3 While holding down the PRESET button, press any of the POSITION buttons, 1 to 6, in which you want to store the settings.

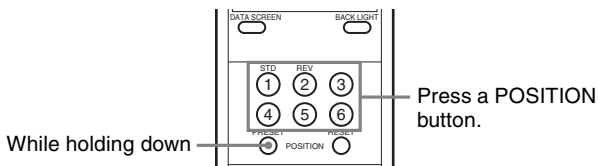

The message "PRESET No.xx" (selected POSITION number) is output from the composite video output or S video output connector and is displayed for about 2 seconds.

To recall the stored settings

Press any of the POSITION buttons, 1 to 6, in which you have stored the settings.

To cancel the preset memory

While holding down the RESET button, press the POSITION button from which you want to cancel the settings.

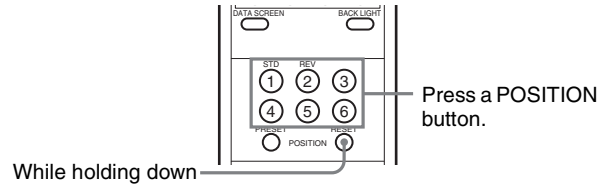

Notes

- When the power is turned on, the camera starts with the settings stored in POSITION 1.
- If you want to retain the previous pan and tilt positions when the power is turned off and turned on again, store those positions in POSITION 1.
- Storing or canceling the settings in POSITION 1 takes about 2 seconds longer than those of other positions.
- When you are storing or canceling the settings in one POSITION, you cannot call up, store or cancel the settings in another POSITION.

Operation Using the RM-BR300 Remote Control Unit

Before operating, check that the camera, the RM-BR300 Remote Control Unit and peripheral devices are properly installed and connected.

For details, see “Installation” (page 42) and “Connections” (page 46).

Turning on the Power

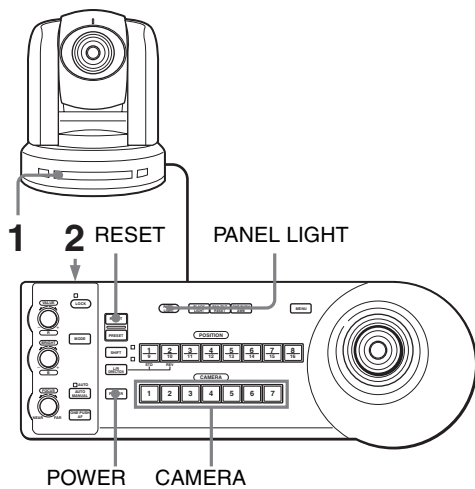

- 1 Connect the camera to an AC outlet using the supplied AC power adaptor and power cord. The power is turned on and the POWER lamp lights. The camera will automatically pan and tilt and be reset to the position stored in POSITION 1 (Pan/tilt reset action).
- 2 Press the ON/OFF switch on the RM-BR300 Remote Control Unit to turn it on. The CAMERA button representing the camera whose power was turned off last lights. (CAMERA 1 button lights by default.)
- 3 Turn on the peripheral devices.

Note

Be sure to turn on the power of the camera before the power of the Remote Control Unit. Otherwise, the Remote Control Unit cannot recognize the connected camera.

To turn on/off the camera using the RM-BR300 Remote Control Unit

As long as the camera is connected to an AC outlet, you can turn the camera on or off with the POWER button on the Remote Control Unit.

While holding down the POWER button, press the CAMERA button corresponding to the camera whose power you want to turn on/off.

When you turn the power off using the Remote Control Unit, the POWER lamp turns off and the STANDBY lamp lights on the camera.

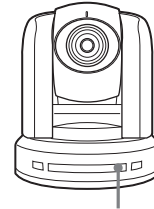

STANDBY lights.

To illuminate the panel of the Remote Control Unit

Press the PANEL LIGHT button. All the POSITION buttons and CAMERA buttons light.

To turn off the illumination, press the PANEL LIGHT button again.



Operating Multiple Cameras

Before operating, you must assign the camera addresses to the connected cameras as follows. Then you can switch the camera to be controlled simply by pressing the corresponding CAMERA button.

To assign camera addresses automatically

- 1 Make sure that the camera address selectors on the bottom of each camera are set to "0."

For setting the camera address selectors, see page 16.

- 2 Turn on the power of all the connected cameras and the RM-BR300 Remote Control Unit.

- 3 Hold down the RESET button and press the POWER button on the Remote Control Unit. The Remote Control Unit recognizes the connected cameras and assigns them camera addresses 1 to 7 automatically in the connected order.
- 4 Press the POWER button on the Remote Control Unit and check that the CAMERA buttons light. The number of the lit CAMERA buttons indicates how many cameras have the addresses assigned. Now you can switch the camera you want to control with the Remote Control Unit by pressing the CAMERA button.

To assign camera addresses manually

Set one of the camera addresses, 1 to 7, using the camera address selectors on the bottom of each camera.

For setting the camera address selectors, see page 16

Pan/Tilt and Zoom Operation

Panning and Tilting

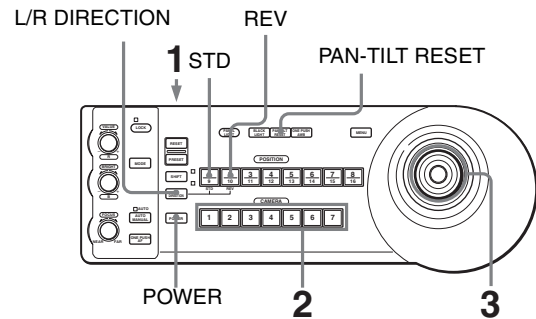

- 1 Turn on the power of the camera and the RM-BR300 Remote Control Unit. The camera will turn on, performing the pan/tilt reset action automatically.
- 2 Press the CAMERA button corresponding to the camera you want to operate.
- 3 Operate the joystick to pan or tilt the camera. While checking the picture on the screen, incline the joystick in the desired direction. The panning/tilting speed changes according to the angle at which you incline the joystick. Release the joystick to stop panning/tilting.

To face the camera back to the front

Press the button on the top of the joystick for one or two seconds.

Press for 1 or 2 seconds.

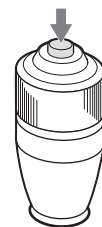





If you accidentally move the camera with your hand

Press the PAN-TILT RESET button to perform the pan/tilt reset action.

If the camera moves in a different direction from that you intended

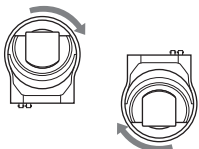
The camera is preset to face toward the right whenever the joystick is inclined to the right. You might wish to face the camera toward the opposite direction from that in which you inclined the joystick, for example, when you change the direction of the camera while checking the picture on the screen. In such a case, press the POSITION 2 (REV) button while holding down the L/R DIRECTION button.

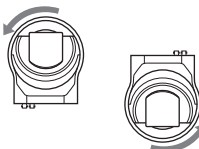
To reset the setting, press the POSITION 1 (STD) button while holding down the L/R DIRECTION button.

Joystick	Movement of the camera	Setting
Incline to the right.		While holding down   Press.
Incline to the right.		While holding down   Press.

Note

The setting above only changes the signal emitted from the RM-BR300 Remote Control Unit, and does not change the setting of the camera itself.

If the STANDBY lamp of the camera flashes

When the camera is moved or turned by hand or by external shock, the microcomputer inside the camera may not be able to memorize the pan/tilt position properly.

To reset the pan/tilt position, press the PAN-TILT RESET button.

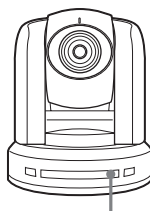

STANDBY flashes.

Zooming

Turn the dial on the upper part of the joystick.

Subject appears farther away. (Wide angle)

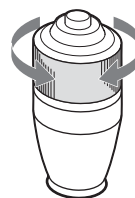

Subject appears closer. (Telephoto)

Note

When you perform pan/tilt operation while the camera is in the telephoto mode, the moving speed of the image on the screen may be a little jerky.

Adjusting the Camera

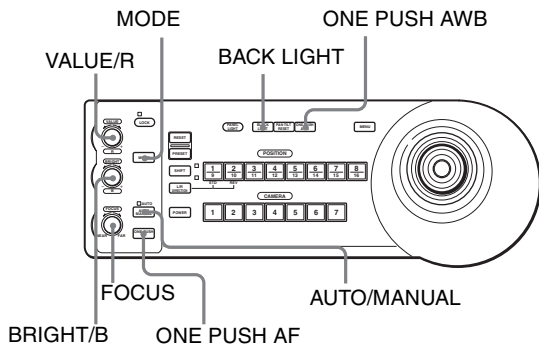

Focusing on a Subject

To focus the camera on a subject automatically

Press the AUTO/MANUAL button so that the AUTO indicator lights. The camera focuses on the subject in the center of the screen automatically.



To focus the camera on a subject manually

Press the AUTO/MANUAL button so that the AUTO indicator turns off. Then turn the FOCUS control clockwise or counterclockwise to have the camera focus on the subject.

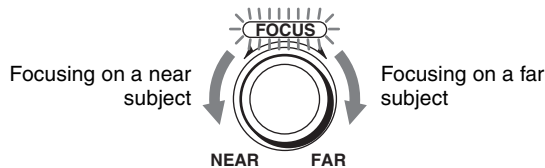

One-push auto focusing during manual focus adjustment

Press the ONE PUSH AF button. The camera focuses on the subject in the center of the screen automatically.



Shooting with Back Lighting

When you shoot a subject with a light source behind it, the subject becomes dark. In such a case, press the BACK LIGHT button.

To cancel the function, press the BACK LIGHT button again.



Note

The BACK LIGHT function is effective only when MODE is set to FULL AUTO in the EXPOSURE menu of the camera.

Adjusting the White Balance

Before adjusting the white balance, shoot a white object under the same lighting conditions as the subject you want to shoot, and zoom it in on the screen. (You can use a white wall, etc., instead of the object.)

To adjust the white balance automatically

- 1 Set MODE to ONE PUSH in the WHITE BALANCE menu of the camera.

For setting, see “WHITE BALANCE Menu” on page 27.

- 2 Press the ONE PUSH AWB button. The white balance is adjusted automatically.



To adjust the white balance manually

- 1 Set MODE to MANUAL in the WHITE BALANCE menu of the camera.

For setting, see “WHITE BALANCE Menu” on page 27.

- 2 Press the MODE button so that the R and B indicators on the VALUE/R and BRIGHT/B controls light (White balance adjustment mode).

- Adjust the red gain with the R control and the blue gain with the B control.

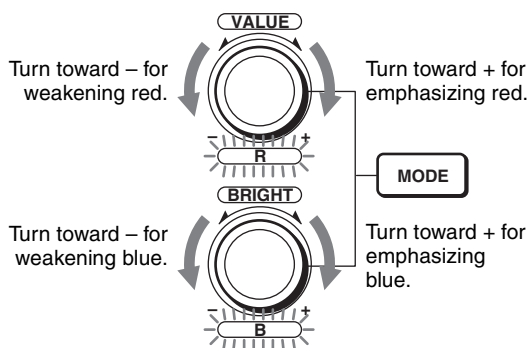

Adjusting the Brightness

- Set MODE to SHUTTER Pri, IRIS Pri, BRIGHT or MANUAL in the EXPOSURE menu of the camera.

For setting, see “EXPOSURE Menu” on page 26.

- Press the MODE button so that the VALUE and B indicators on the VALUE/R and BRIGHT/B controls light (Brightness adjustment mode).
- Adjust the brightness with the VALUE or BRIGHT control.

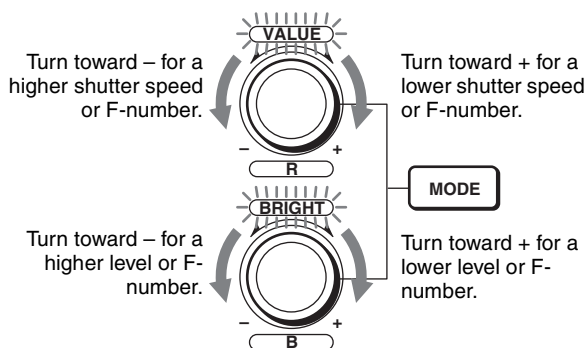

Functions of the VALUE and BRIGHT controls

The functions of the VALUE control and the BRIGHT control change according to the MODE setting in the EXPOSURE menu, as follows:

MODE setting	Function of VALUE control	Function of BRIGHT control
FULL AUTO	Not used	Exposure compensation level control*
SHUTTER Pri	Shutter speed control	Exposure compensation level control*
IRIS Pri	Iris control	Exposure compensation level control*
BRIGHT	Not used	Brightness level control
MANUAL	Shutter speed control	Iris control

* When EX-COMP is ON in the EXPOSURE menu

Storing the Camera Settings in Memory

– Presetting Feature

Up to sixteen combinations of settings (sixteen positions), including camera position, zooming, focusing, and backlighting, can be stored in the memory of the camera using the RM-BR300 Remote Control Unit.

The number of positions that can be stored depends on the camera model. You can store up to six positions on a BRC-300/300P camera.

For details of the camera settings to be preset, see “Presetting Items” on page 59.

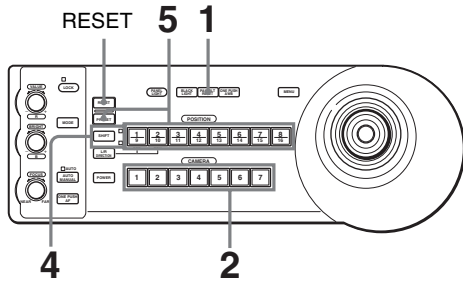

- 1** Press the PAN-TILT RESET button to reset the pan/tilt position.
- 2** Press the CAMERA button to select the camera whose settings you want to preset.
- 3** Adjust the position, zooming, focusing and backlighting of the camera. (See page 36 to 39.)
- 4** Press the SHIFT button to select the function of POSITION 1 to 8 buttons, if necessary.
To store in positions 1 to 8, press the SHIFT button so that the upper indicator lights. The POSITION 1 to 8 buttons can be used for positions 1 to 8.
To store in positions 9 to 16, press the SHIFT button so that the lower indicator lights. The POSITION 1 to 8 buttons can be used for positions 9 to 16.

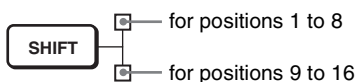

- 5** While holding down the PRESET button, press any of the POSITION buttons, 1 to 8, in which you want to store the settings.

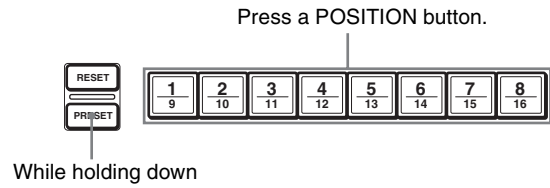

The settings are stored in the memory of the camera.

The pressed button flashes during storing. Flashing stops when storing is completed.

To recall the stored settings

Select the function of the POSITION 1 to 8 buttons using the SHIFT button, if necessary. Press any of the POSITION buttons, 1 to 8, in which you have stored the settings.

To cancel the preset memory

Select the function of the POSITION 1 to 8 buttons using the SHIFT button, if necessary. While holding down the RESET button, press the POSITION button from which you want to cancel the settings.

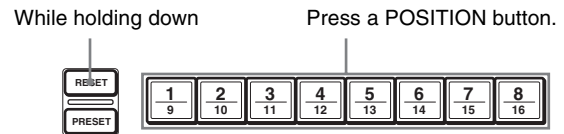

The pressed button flashes during canceling of the settings. Flashing stops when the settings have been canceled.

Notes

- When the power is turned on, the camera starts with the settings stored in POSITION 1.
- If you want to retain the previous pan and tilt positions when the power is turned off and turned on again, store those positions in POSITION 1.
- When you are storing or canceling the settings in one POSITION, you cannot call up, store or cancel the settings in another POSITION.

Setting the Speed of the Camera Moving to a Preset Position

You can select the panning/tilting speed when the camera moves to a preset position.

- 1** Press the CAMERA button to select the camera whose speed you want to set.
- 2** Press the POSITION button for which you want to set the speed for more than one second.
All the CAMERA buttons, 1 to 7, flash.
- 3** Press one of the CAMERA buttons to select the speed.

CAMERA button	Panning/tilting speed
1	1 degree/sec.
2	2.2 degrees/sec.
3	4.8 degrees/sec.
4	11 degrees/sec.
5	23.3 degrees/sec.
6	43 degrees/sec.
7	60 degrees/sec. (default)

Now the camera will move to the position preset to the pressed POSITION button with the selected speed.



Installation

Attaching an Interface Card

Attach an interface card (not supplied) to the card slot on the rear of the camera.

- 1 Loosen the two screws to remove the card slot cover.

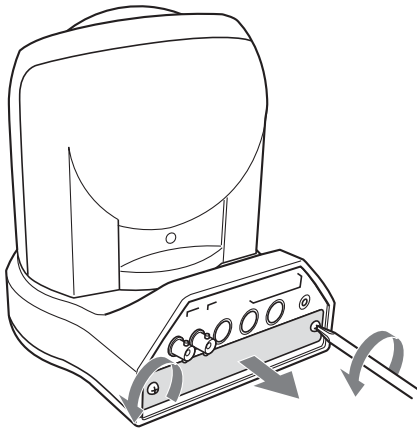

- 2 Insert an optional interface card into the card slot. Align both ends of the interface card with the sliders inside the slot, then insert the card securely as far as it will go.

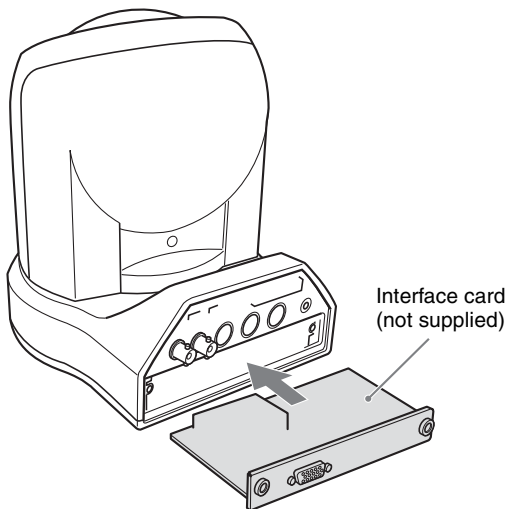

- 3 Tighten the two screws on the interface card.

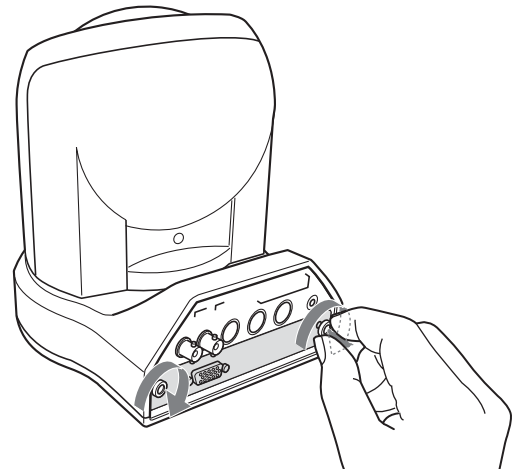

To remove the interface card

Loosen the two screws on the interface card and pull the card out straight and slowly.

Installing the Camera

To install the camera on a desk

Place the camera on a flat surface.

If you have to place the camera on an inclined surface, make sure that the inclination is less than ± 15 degrees, so that the pan/tilt performance is guaranteed, and take an appropriate countermeasure to prevent the camera from falling.

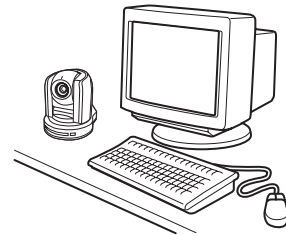

Notes

- Do not grasp the camera head when carrying the camera.
- Do not turn the camera head by hand. Doing so will result in the camera malfunctioning.

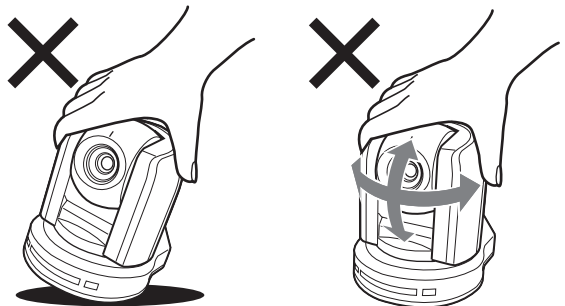

To attach the camera to a tripod

Attach a tripod to the screw hole used for attaching a tripod on the bottom of the camera. The tripod must be set up on a flat surface and tightened firmly by hand. Use a tripod with screws meeting either of the following specifications.

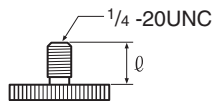

ISO standard: $l = 4.5 \text{ mm} \pm 0.2 \text{ mm}$
 ASA standard: $l = 0.197 \text{ inches}$

To attach a wide conversion lens

The camera's lens portion is threaded. To attach a wide conversion lens, align the lens with those threads, and turn it clockwise to attach it securely.

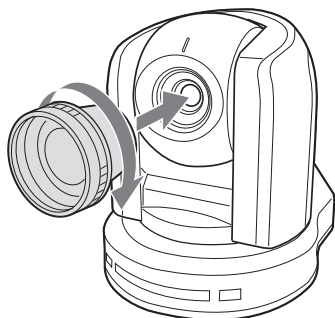

Acceptable wide conversion lenses

Weight: less than 200 g (7 oz)
 Size: less than the size given in the illustration below

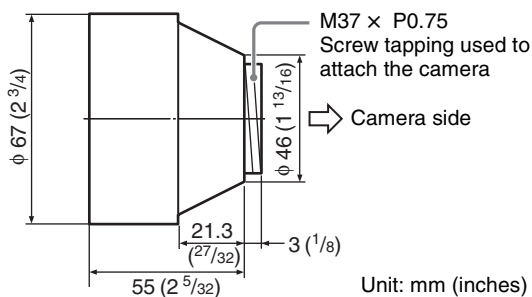

Vignetting may occur when shooting with the conversion lens attached.

Notes

In order to prevent the wide conversion lens from falling, note the following:

- Entrust this task an experienced contractor or installer to ensure the wide conversion lens does not come loose and fall.

- Be sure that the lens is tightened securely, as far as it will go and it does not fall.
- Do not use a wide conversion lens in an environment where it is subject to vibration or shock.
- Check periodically, at least once a year, to ensure that the connection has not loosened. If conditions warrant, make this periodic check more frequently.

Installing the Camera on the Ceiling

Using the supplied ceiling brackets, wire rope and screws, you can utilize existing junction boxes, etc., to attach the camera to the ceiling. When you install the camera, always install it on a level ceiling. If you have to install it on an inclined ceiling, make sure that the inclination is within ± 15 degrees, so that the pan/tilt performance is guaranteed.

Notes

- When you attach the camera to the ceiling, entrust the installation to an experienced contractor or installer.
- Attach the camera to the ceiling firmly, after making sure the ceiling is strong enough to bear the weight of the camera plus the ceiling bracket. If the ceiling is not strong enough, the camera may fall and cause serious injury.
- Be sure to attach the supplied wire rope to prevent the camera from falling.
- Check periodically, at least once a year, to ensure that the connection has not loosened. If conditions warrant, make this periodic check more frequently.

Before installation

After deciding the shooting direction, make the required holes for the junction box and connecting cables on the ceiling.

Note

The connecting cables cannot be passed through the ceiling bracket (A). A hole for the wiring is required in the ceiling at the back of the camera where it is attached to the ceiling.

Installation

- 1 Set IMG-FLIP to ON in the SYSTEM menu.
- 2 Loosen the four screws on the bottom of the camera to remove the four feet.

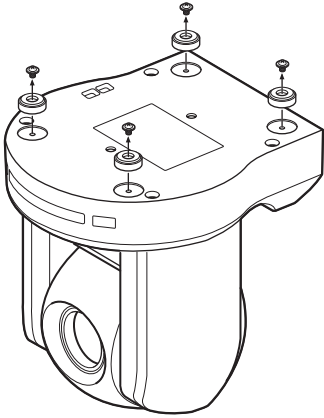

- 3 Attach the wire rope to the junction box on the ceiling. Use an appropriate screw (not supplied) to attach the wire rope to the junction box.

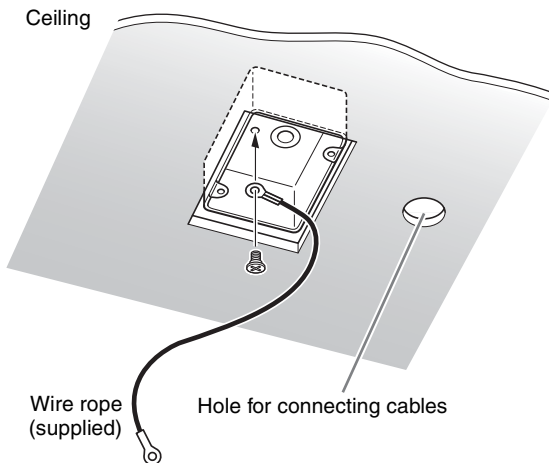

- 4 Attach the ceiling bracket (B) to the junction box on the ceiling. Align the holes in the bracket with those in the junction box, and use appropriate screws (not supplied).

There are three screw holes along the edges of the ceiling bracket (B). Later, the front of the camera will be positioned at one of the screw holes. Adjust the direction of the ceiling bracket (B) so that the camera will face the front and attach the bracket securely.

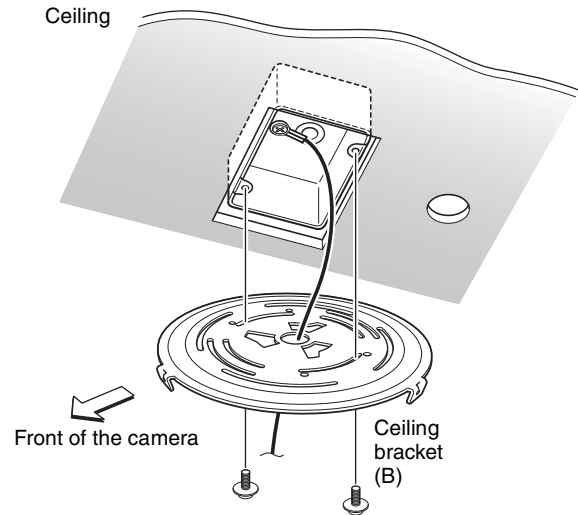

- Attach the ceiling bracket (A) to the bottom of the camera using the supplied four screws (+M3 × 8). Align the screw holes on the bottom of the camera with those in the ceiling bracket, and attach the bracket to the camera.

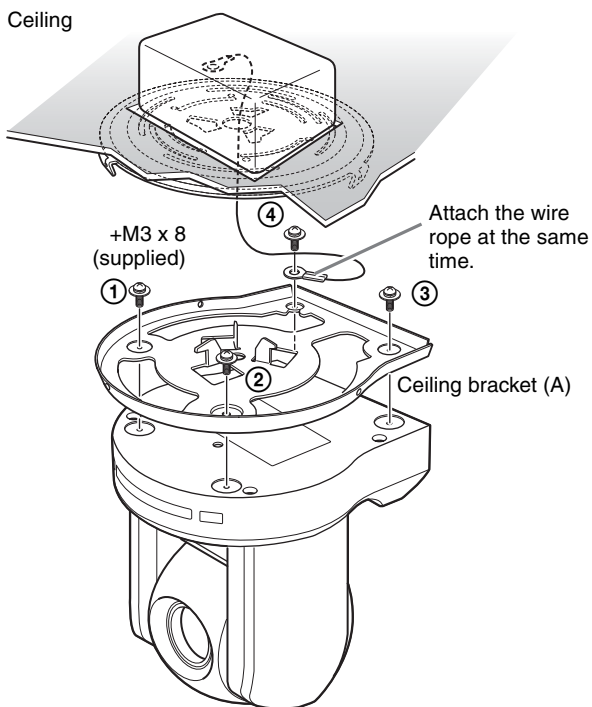

Tighten the screws a little at a time in the numbered order shown in the illustration. Attach the wire rope using the screw designated as number ④ above. After all of the screws have been temporarily tightened, securely tighten each one in turn.

Note

For attaching the camera to the ceiling brackets, use only the supplied screws. Using other screws may damage the camera.

- Insert the protrusions on the ceiling bracket (A) into the spaces prepared in the ceiling bracket (B), and temporarily attach them by turning the ceiling bracket (A) with the camera clockwise.

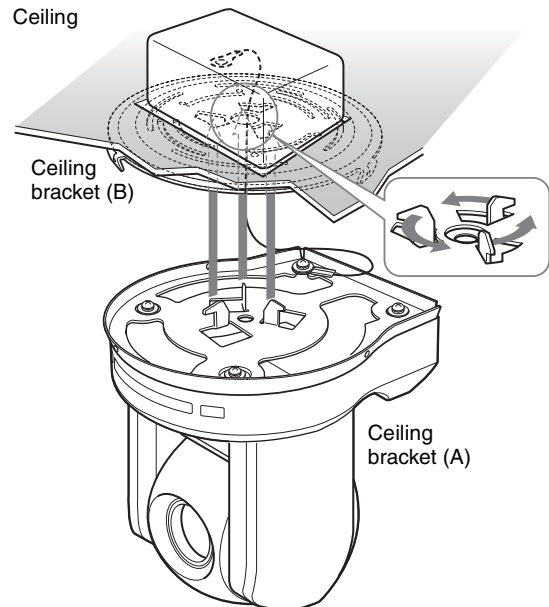

- Secure the ceiling brackets (A) and (B) using the supplied three screws (+M3 × 8).

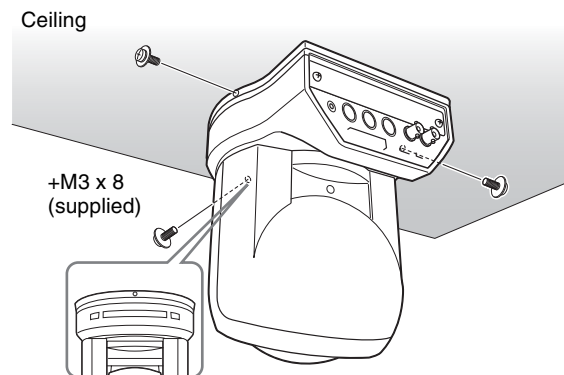

- 8** Connect the cables to the connectors on the rear of the camera.

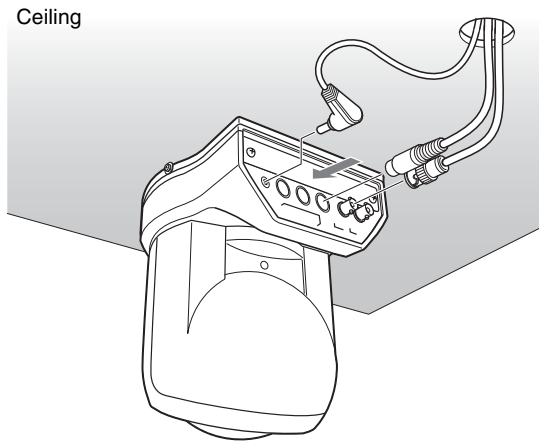

Note

Take the proper steps to ensure that the load of the cables connected does not cause problems.

To remove the camera

- 1** Remove the three screws used to attach the camera in step 7 of "Installation."
- 2** Turn the camera with the bracket counterclockwise to remove.

Connections

Connecting to an AC Outlet

Use the supplied AC power adaptor and AC power cord to connect the camera to an AC outlet.

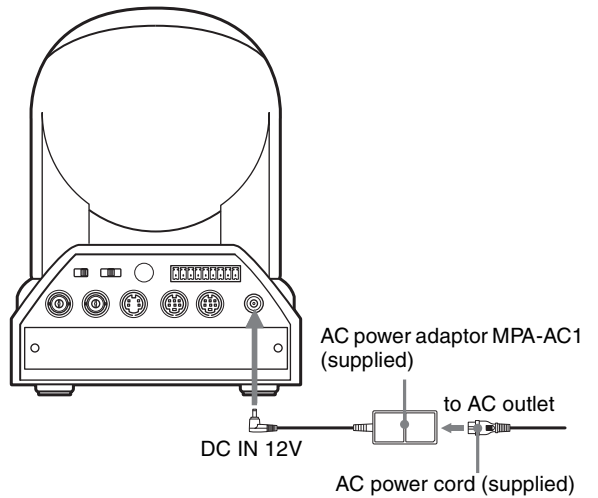

Connecting the RM-BR300 Remote Control Unit

Use the RS-232C connecting cable supplied with the Remote Control Unit.

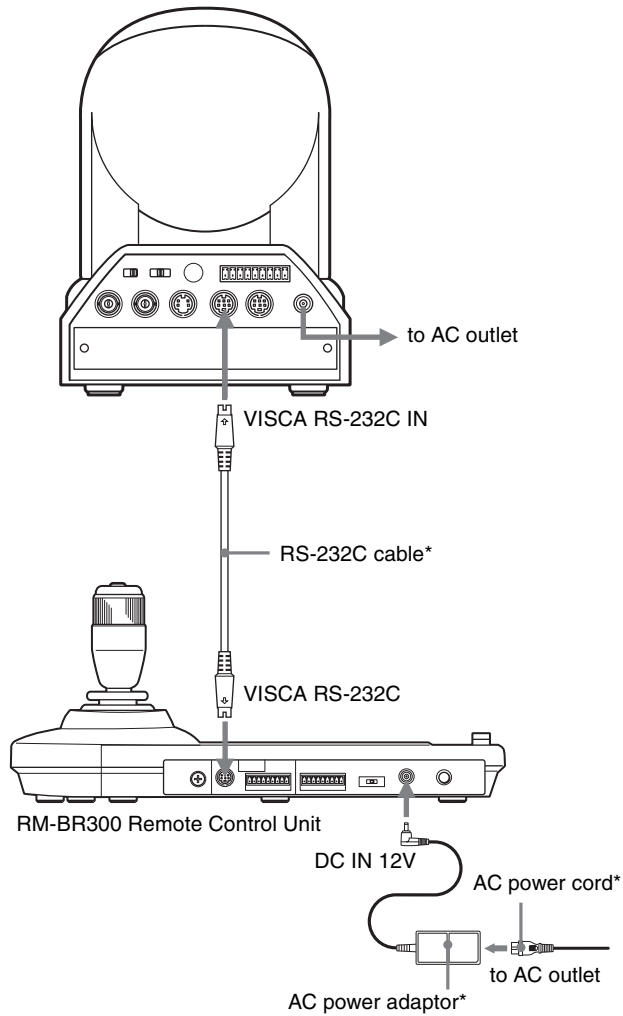

* supplied with the RM-BR300

Note

When using the VISCA RS-232C connectors, check that the **BOTTOM** switch on the bottom of the camera (page 16) and the DIP switch on the bottom of the Remote Control Unit (page 20) are set to RS-232C.

To connect the Remote Control Unit using the VISCA RS-422 connectors

You can use the VISCA RS-422 connectors to connect the RM-BR300 Remote Control Unit to the camera instead of the VISCA RS-232C connectors. Use of the VISCA RS-422 connectors allows the connection up to 1,200 m (3,937 feet) away.

Prepare the connecting cable using the RS-422 connector plugs that come with the camera and the Remote Control Unit.

For making the cable, refer to the pin assignments of the VISCA RS-422 connector (page 64) and the wiring diagram of VISCA RS-422 connection (page 64).

For the use of the RS-422 connector plugs, see page 68.

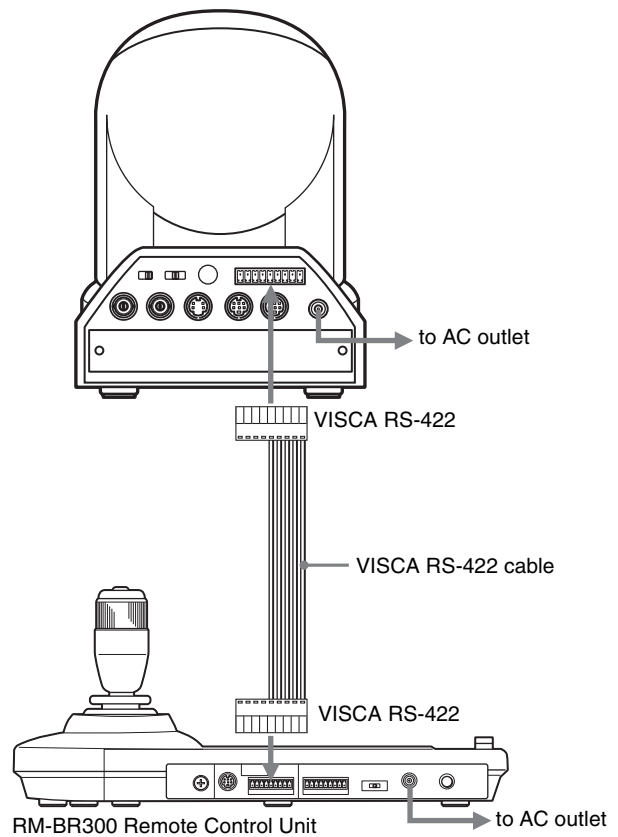

Notes

- When using the VISCA RS-422 connectors, check that the **BOTTOM** switch on the bottom of the camera (page 16) and the DIP switch on the bottom of the Remote Control Unit (page 20) are set to RS-422.
- When the connections using the VISCA RS-422 connectors are made, the VISCA RS-232C connection is not available.

Connecting a Video Monitor, VTR, etc. Equipped with the Composite Video Input Connector

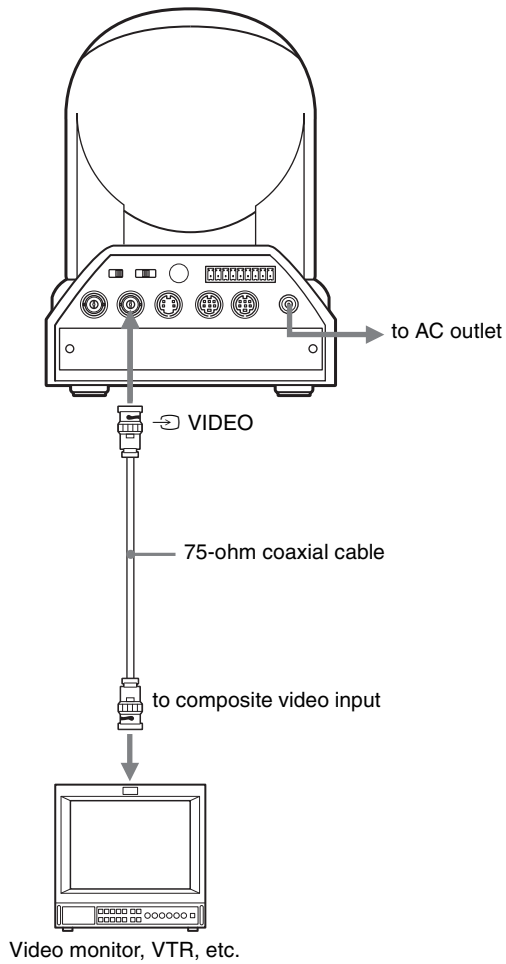

Connecting a Video Monitor, VTR, etc. Equipped with the S-Video Input Connector

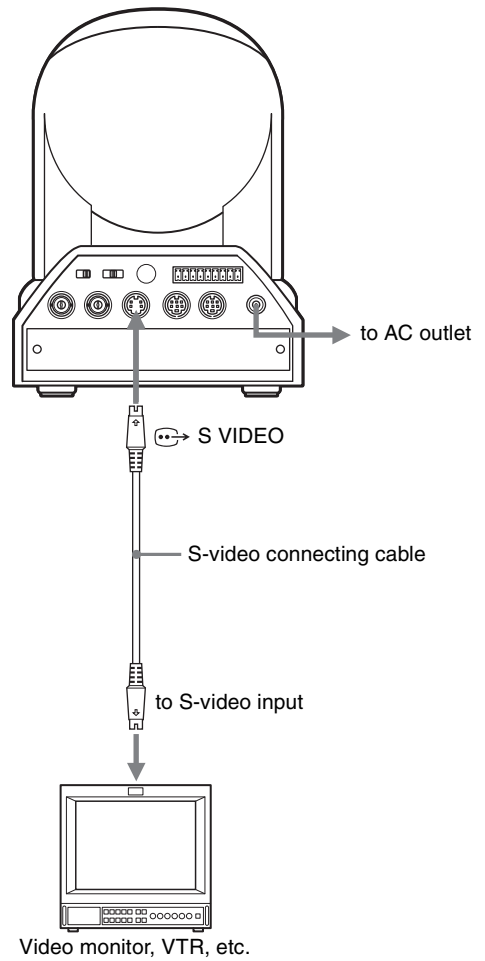

Connecting a Device Equipped with VISCA RS-232C Connector

Connections with the VISCA RS-232C cables (cross type) enable control of multiple cameras with a single RM-BR300 Remote Control Unit.

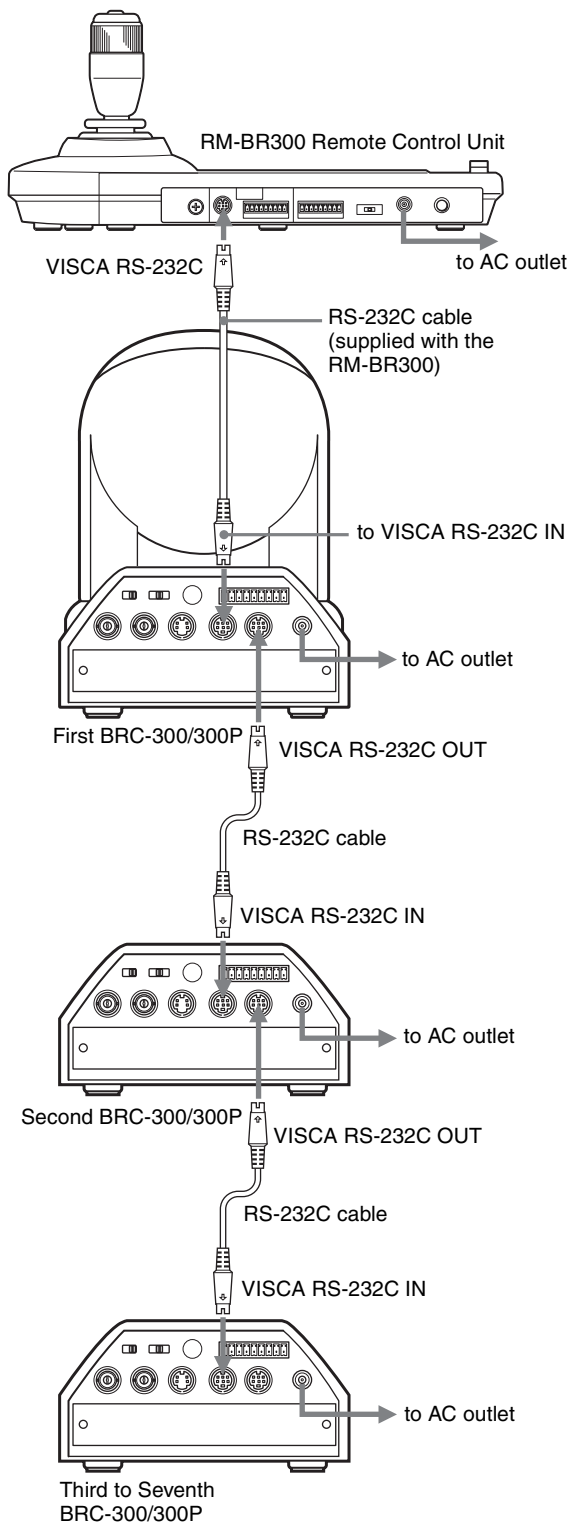

You can connect the camera to a computer equipped with the VISCA RS-232C connector instead of the connection to the RM-BR300 Remote Control Unit.

Note

When using the VISCA RS-232C connectors, check that the BOTTOM switch on the bottom of the camera (page 16) and the DIP switch on the bottom of the Remote Control Unit (page 20) are set to RS-232C.

Connecting a Device Equipped with VISCA RS-422 Connector

Connection via the VISCA RS-422 connectors enables control of multiple cameras. This allows the connection up to 1,200 m (3,937 feet) away.

Prepare the connecting cable using the RS-422 connector plugs that come with the camera and the Remote Control Unit.

For making the cable, refer to the pin assignments of the VISCA RS-422 connector (page 64) and the wiring diagram of VISCA RS-422 connection (page 64). For the use of the RS-422 connector plugs, see page 68.

Notes

- When using the VISCA RS-422 connectors, check that the BOTTOM switch on the bottom of the camera (page 16) and the DIP switch on the bottom of the Remote Control Unit (page 20) are set to RS-422.
- When the connections using the VISCA RS-422 connectors are made, the VISCA RS-232C connection is not available.
- Do not make the VISCA RS-422 connection and the VISCA RS-232C connection simultaneously. If both cables are connected simultaneously, the camera may malfunction.

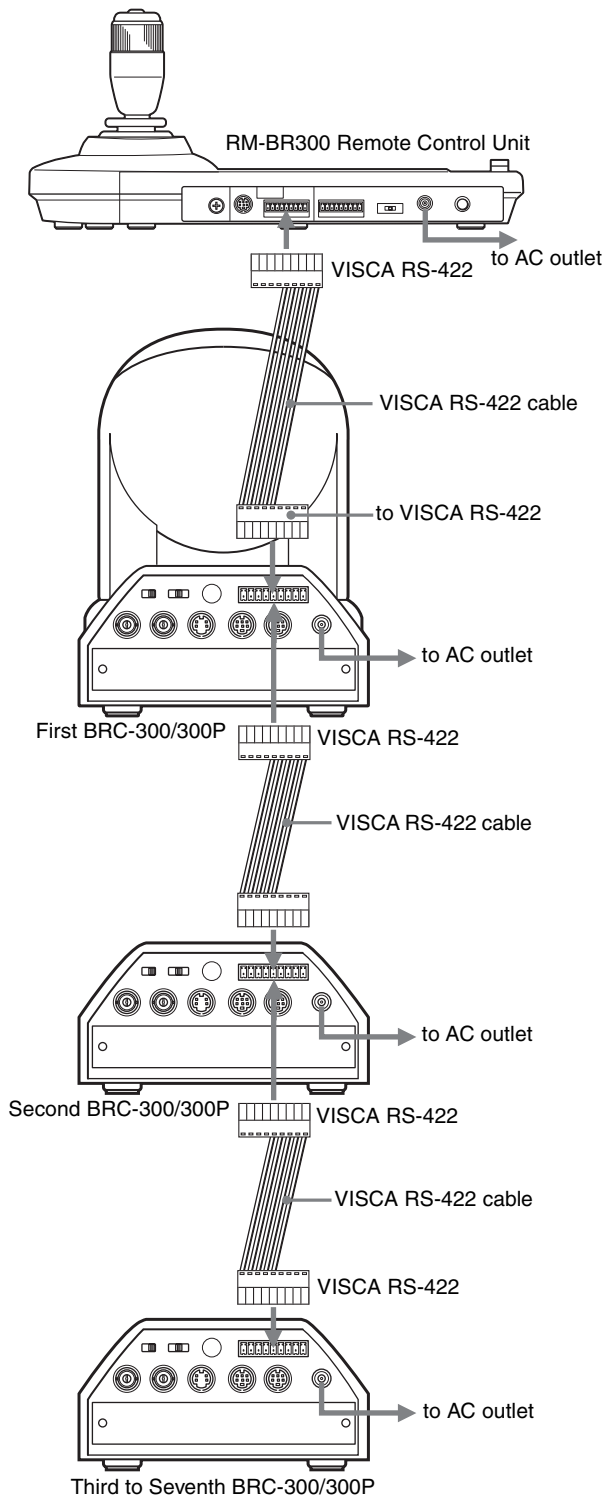

Connecting a Video Monitor Equipped with Analog RGB/Component Connectors

When you install an optional BRBK-301 Analog RGB Component Card into the camera, you can output the signal from the camera by converting it into component video, RGB, composite video or S-video signal.

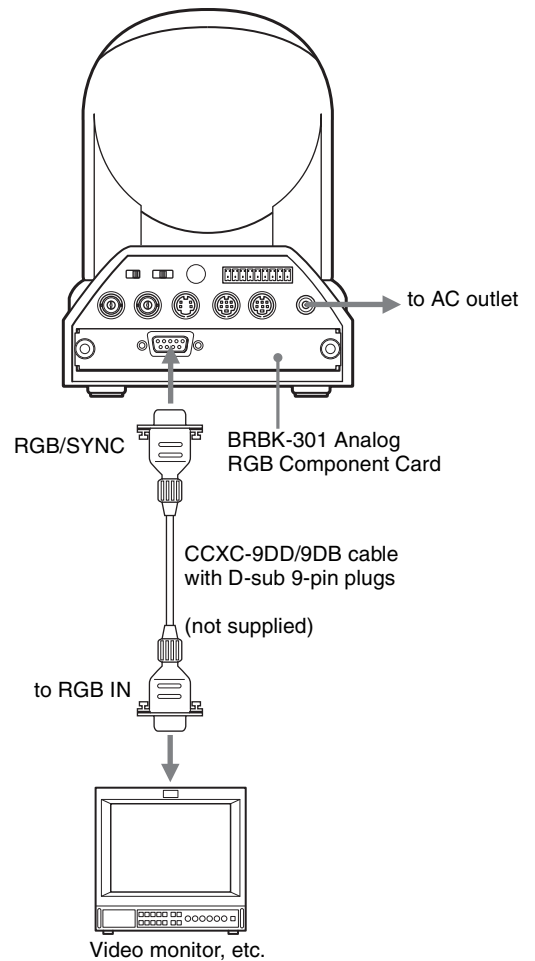

For details on how to attach the BRBK-301 Analog RGB Component Card, see page 42.

To select the output signal, use the OUTPUT1 and OUTPUT2 items in the ANALOG OUT menu (page 30).

Connecting a VTR Equipped with SDI Input Connector

When you install an optional BRBK-302 SDI Card into the camera, you can output the signal from the camera by converting it into a signal compliant with the SDI standard (SMPTE 259M serial digital interface).

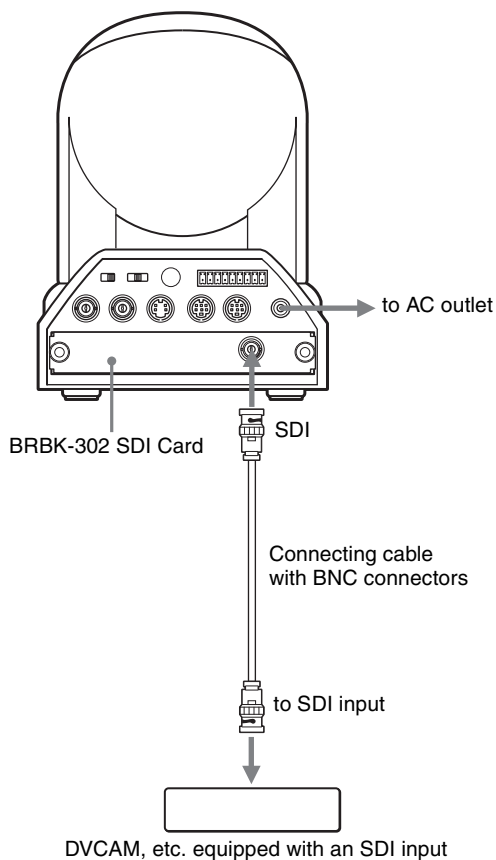

Connecting the BRU-300/300P Optical Multiplex Unit

When you install an optional BRBK-303 Optical Multiplex Card into the camera, you can connect the camera to the BRU-300/300P Optical Multiplex Unit using the CCFC-M100 Optical Fiber Cable. This allows you to control the camera from up to 500 m (1,640 feet) away.

Notes

- When the connection using the Optical Fiber Cable is made, the VISCA RS-232C and VISCA RS-422 connectors on the camera cannot be used.
- When using the VISCA RS-232C connectors or VISCA RS-422 connectors, check the VISCA FUNCTION switch on the rear of the Optical Multiplex Unit (page 21) and the DIP switch on the

bottom of the Remote Control Unit (page 20) are set to RS-232C or RS-422 correctly.

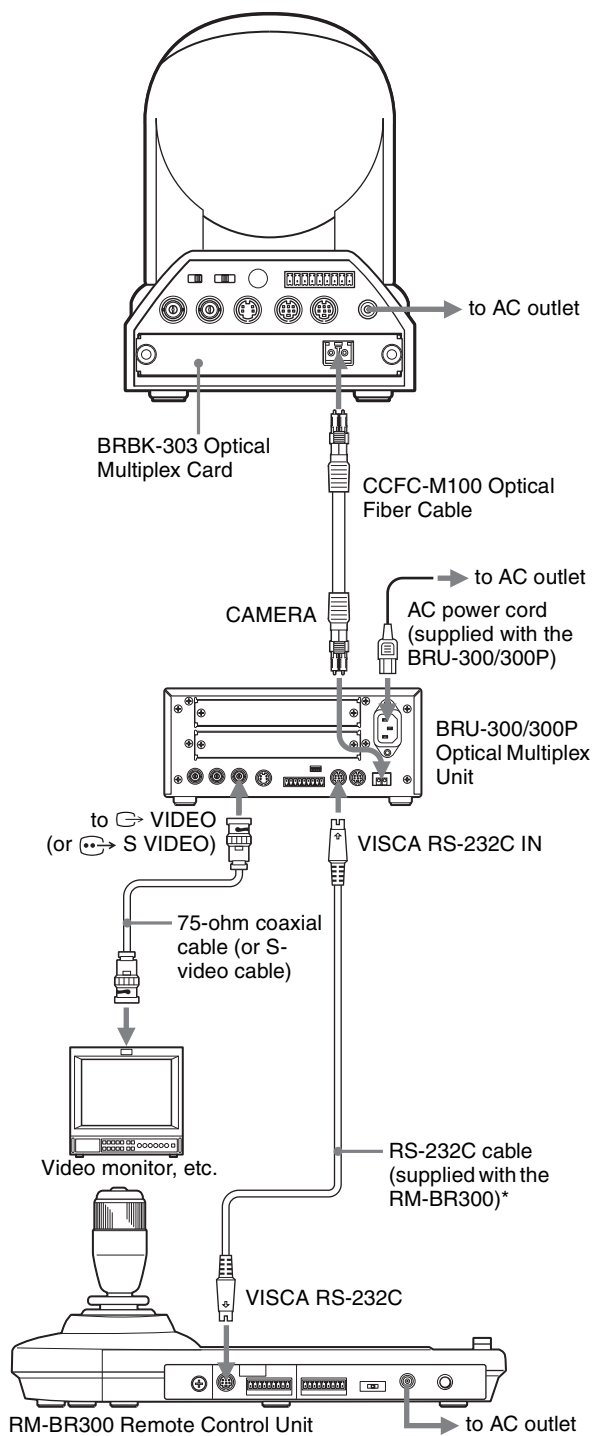

* The VISCA RS-422 connection is also available if you use the VISCA RS-422 connectors.

Notes on use of the CCFC-M100 Optical Fiber Cable

- In order to prevent cable transmission loss, fix the bend in the cable keeping more than 40 mm (1 5/8 inches) radius.

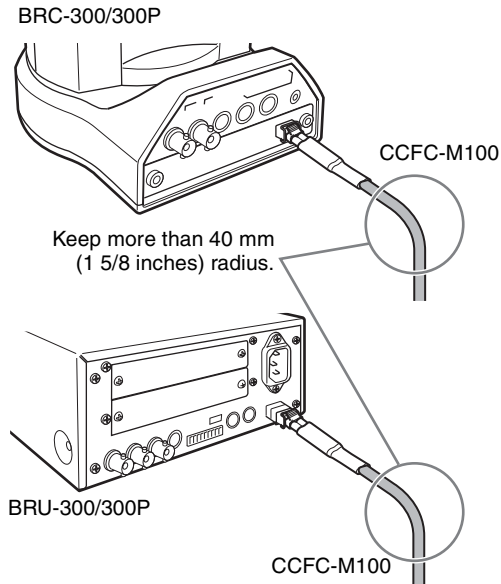

- To connect two Optical Fiber Cables, use the extension plug supplied with the cable.

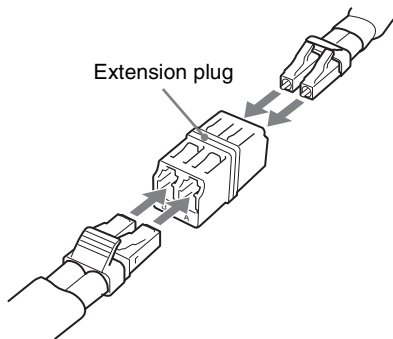

Connecting a Video Switcher

Use a commercially available video switcher to switch between the multiple camera signals to be output.

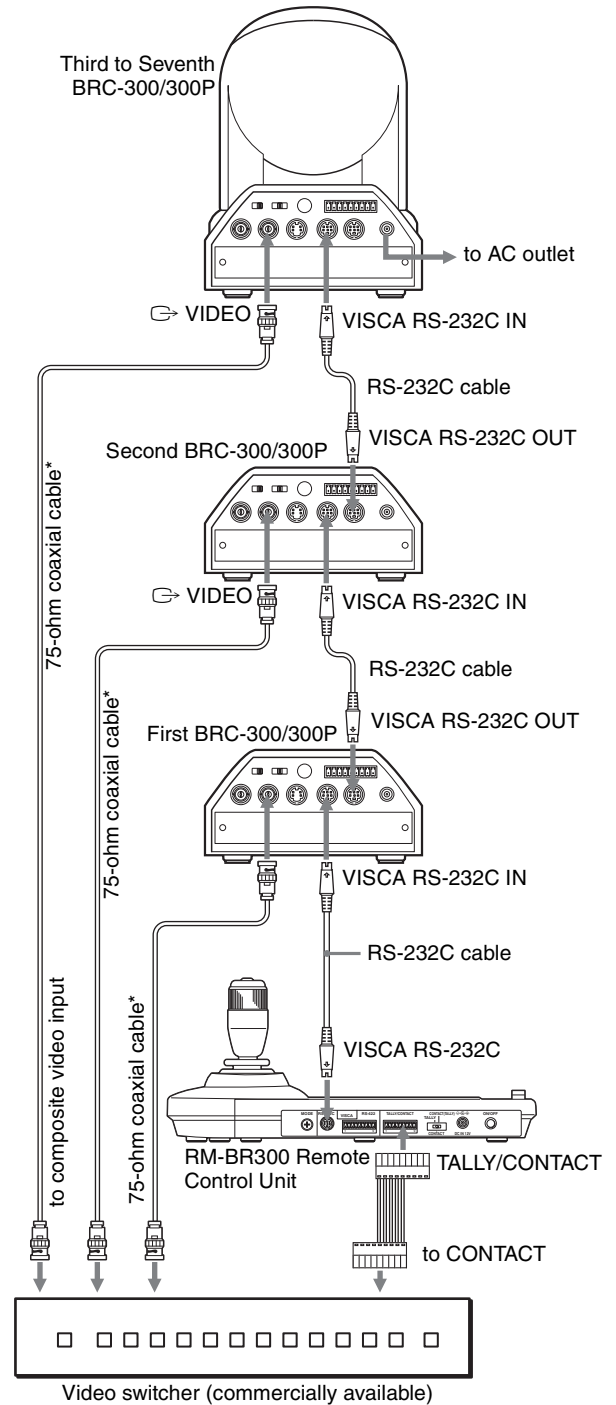

* You can also use an S-video connecting cable to connect the S VIDEO connector on the camera and the S-video input connector on the video switcher.

For connection with a video switcher, refer to the Operating Instructions of the switcher.

Connecting a Sync Signal Generator

To connect a single camera

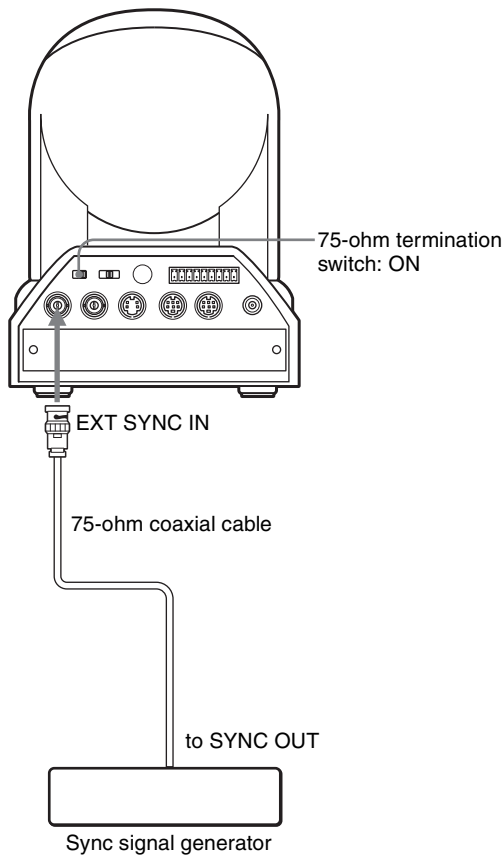

To connect multiple cameras

You can connect up to seven cameras.

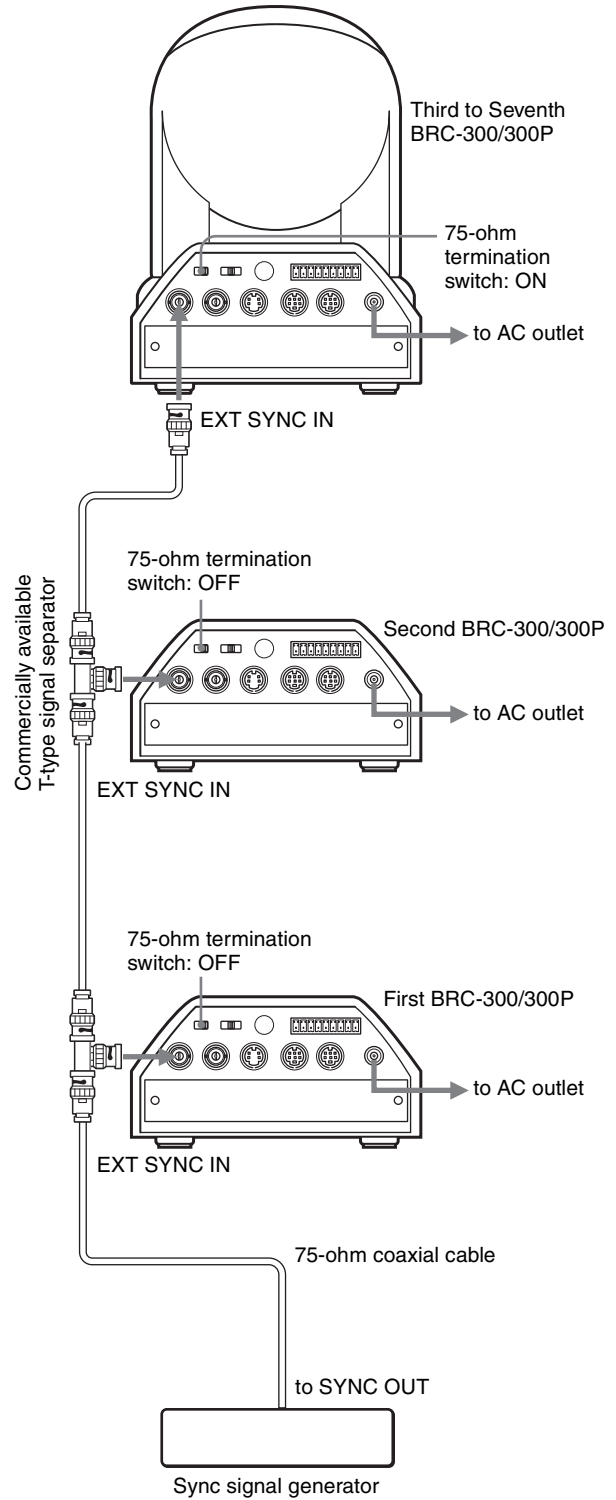

List of Messages

The following messages may appear on the screen. Take the necessary measures shown below.

Indicators on the BRC-300/300P camera

Indicator	Meaning/remedies
STANDBY lamp flashes.	The camera stopped moving due to an error in the pan/tilt mechanism. Reset the pan/tilt position or turn off the power of the camera and turn it on again.

Messages for the BRC-300/300P camera

Message	Meaning/remedies
Please restart system	You are prompted to restart the power of the camera after you changed the setting of "IMG-FLIP" in the SYSTEM menu or "D-ZOOM" in the PAN TILT ZOOM menu. Use the POWER switch on the supplied Remote Commander or the POWER button on the RM-BR300 Remote Control Unit to turn the power off, then on. The changed setting becomes effective.
PRESET xx OK (xx = 1 to 6)	When you store the camera settings into the memory (POSITION 1-6), the message will appear for 2 seconds.
White balance active	While the white balance adjustment is automatically adjusted, the message will blink. Wait for a while. When the adjustment is complete, it will disappear.
White balance active Please wait	The message will appear only when you activate the one-push white balance adjustment by pressing the ONE PUSH AWB button on the RM-BR300 Remote Control Unit.

Error messages for the BRU-300/300P Optical Multiplex Unit

Message	Meaning/remedies
Communication error Please check connection	The message will appear when the Optical Multiplex Unit is turned on, if a problem occurs in the connection of the Optical Fiber Cable between the camera and the Optical Multiplex Unit. Turn off the power of the camera and the Optical Multiplex Unit, check the connection of the Optical Fiber Cable and turn the power on again.
Option card error Please check option card	The message will appear when same-type interface cards are inserted into the two card slots on the Optical Multiplex Unit. Turn off the power of the Optical Multiplex Unit and remove either of the cards.

Troubleshooting

Before bringing in your camera for service, check the following as a guide to troubleshoot the problem. If the problem cannot be corrected, consult with your Sony dealer.

Symptom	Cause	Remedy
The power of the camera is not turned on.	The AC power adaptor is not connected to the DC IN 12V jack firmly.	Insert the power cord firmly as far as it will go.
	The AC power cord is not inserted firmly into the AC power adaptor or the AC outlet.	Insert the power cord firmly as far as it will go.
	The BRBK-303 Optical Multiplex Card is inserted into the card slot.	Remove the card from the card slot.
	When using the far distance remote control system with the BRBK-303 Optical Multiplex Card, CCFC-M100 Optical Fiber Cable and BRU-300/300P Optical Multiplex Unit, the Optical Fiber Cable is not properly connected or the Optical Multiplex Unit is not turned on.	Insert the Optical Fiber Cable firmly as far as it will go. Turn on the Optical Multiplex Unit, or plug in the power cord of the multiplex unit to an AC outlet firmly.
The camera cannot be turned on with the supplied Remote Commander.	"IR-RECEIVE" in the SYSTEM menu is set to OFF.	Use the RM-BR300 Remote Control Unit to open the menu and set "IR-RECEIVE" to "ON." (page 29)
The picture is not displayed on the video monitor connected to the camera.	The video cable is not connected properly.	Check the connection between the camera and video monitor.
	The exposure is not set correctly on the camera.	Set the exposure correctly in the EXPOSURE menu.
Pan, tilt or zoom cannot be operated.	Any menu is displayed on the monitor screen.	Press the DATA SCREEN button on the supplied Remote Commander or the MENU button on the RM-BR300 Remote Control Unit to turn off the menu from the monitor screen.
	The panning or tilting range is limited.	Change the "PAN-TILT LIMIT" setting in the PAN TILT ZOOM menu (page 28).
The Remote Commander does not work.	The CAMERA SELECT button you pressed on the Remote Commander does not match the number set with the IR SELECT switch on the camera.	Press the CAMERA SELECT button corresponding to the IR SELECT switch setting on the camera (page 32).
The camera cannot be operated with the RM-BR300 Remote Control Unit.	The connection using the VISCA RS-422 connectors is not correctly made.	Check that the connection to the VISCA RS-422 connectors is correctly made, and the RS-422 cable is properly connected.
	The BOTTOM switch on the bottom of the camera is set to any other address than "0 (AUTO)."	Identify the address of the camera (page 16), then set the MODE selector on the rear of the Remote Control Unit to the same address.
	VISCA control setting is not correct.	Select the proper setting (RS-232C or RS-422) with the BOTTOM switch on the bottom of the camera (page 16) and the DIP switch on the Remote Control Unit (page 20).
	The communication baud rate setting of the camera and the RM-BR300 differ.	Select the same communication baud rate (9600 bps or 38,400 bps) with the BOTTOM switch on the bottom of the camera (page 16) and the DIP switch on the Remote Control Unit (page 20).
	The NC (No Connection) switches are set to ON.	Set switch 1 and camera address selector switch 4 of the BOTTOM switches on the bottom of the camera to OFF (page 16).

Symptom	Cause	Remedy
The VISCA control is not available with a computer connected to the camera.	The computer is not correctly connected to the camera.	<p>Make sure the connection between the computer and camera is made correctly.</p> <p>Check that the VISCA control setting (RS-232C or RS-422) and the baud rate setting (9600 bps or 38,400 bps) are properly made with the BOTTOM switch on the bottom of the camera (page 16) and the DIP switch on the Remote Control Unit (page 20).</p> <p>Try to connect the camera to the RM-BR300 Remote Control Unit to check that the camera works properly.</p>
The picture quality obtained from the camera connected to a computer differs from that from the camera connected to a video monitor.	Depending on your computer or video capture board, you may not be able to obtain the expected picture quality.	Consult with your computer manufacturer or dealer for details.
The camera cannot be operated at all.	—	Pull out the plug of the power cord from the AC outlet, then reinsert it into the AC outlet after a while.



Menu Configuration

The menus of the camera are configured as described below.

The initial settings of each item are in bold.

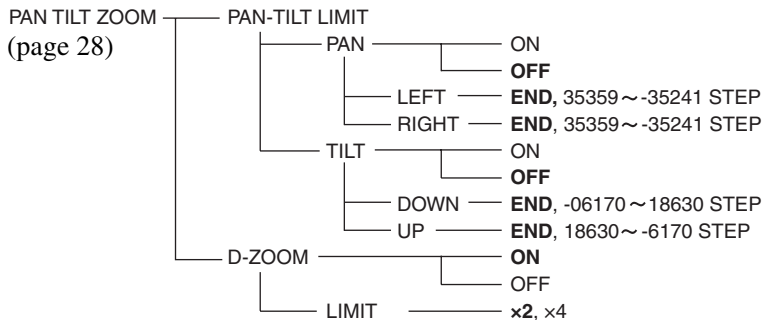
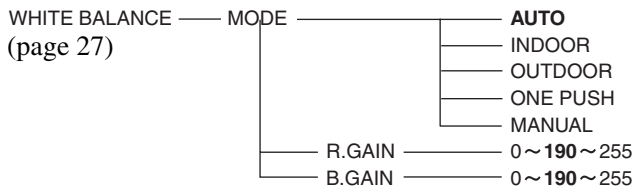
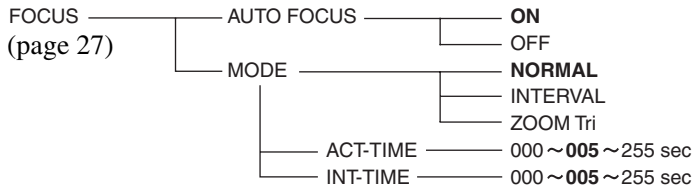
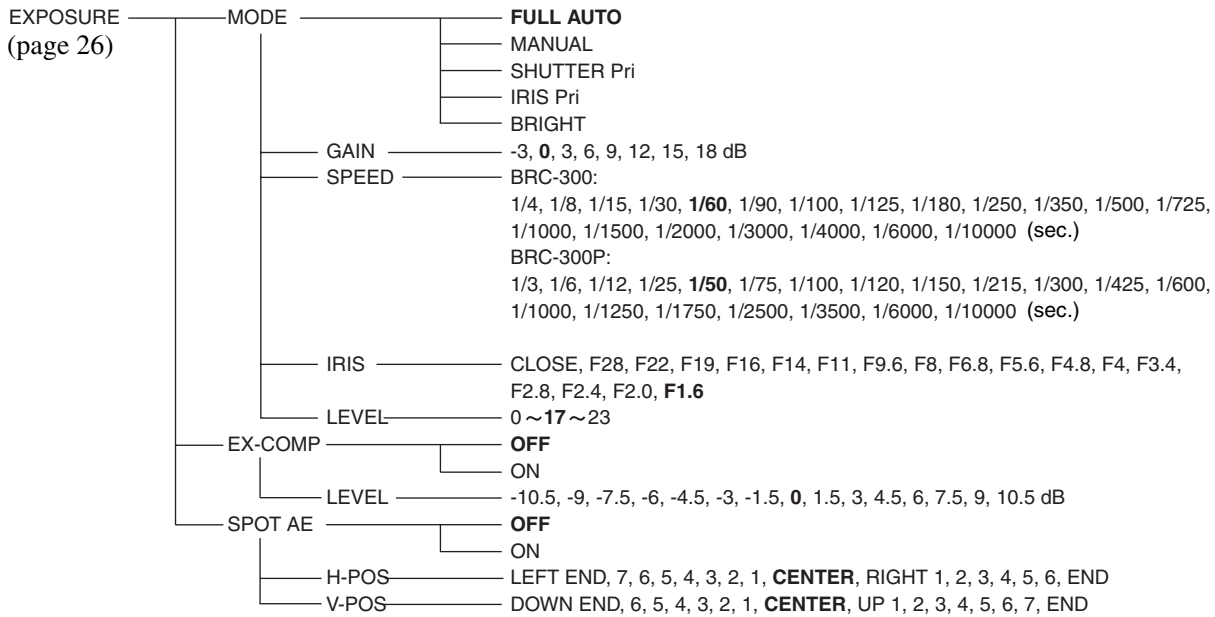

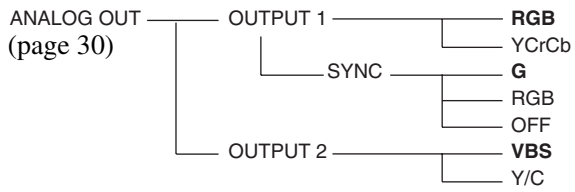
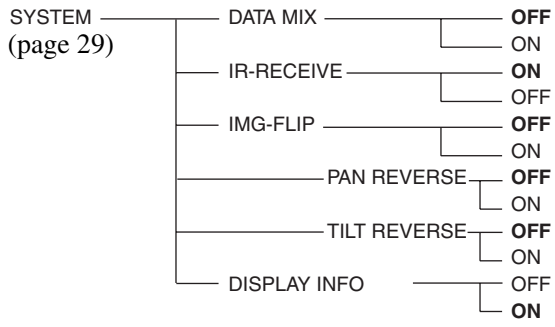
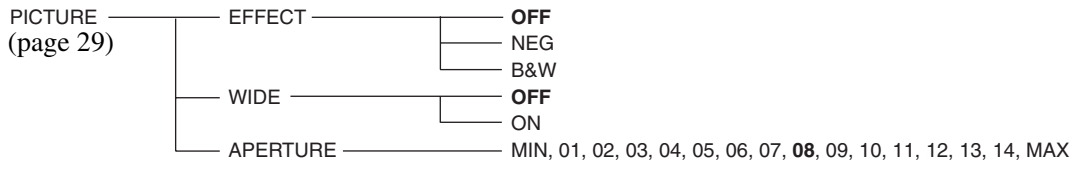

Presetting Items

The following setting items can be stored in the memory of the camera.

Presetting item	Presetting position number					
	1	2	3	4	5	6
Pan/tilt position	○	○	○	○	○	○
Zoom position	○	○	○	○	○	○
Digital zoom on/off	○	○	○	○	○	○
Auto/manual focus mode	○	○	○	○	○	○
Focus position	○	○	○	○	○	○
White balance mode	○	○	○	○	○	○
Red/blue gain setting	○	○	○	○	○	○
Exposure mode	○	○	○	○	○	○
Shutter speed value	○	○	○	○	○	○
Iris value	○	○	○	○	○	○
Gain value	○	○	○	○	○	○
Brightness level	○	○	○	○	○	○
Exposure compensation on/off	○	○	○	○	○	○
Exposure compensation level	○	○	○	○	○	○
Back lighting on/off	○	○	○	○	○	○
Aperture level	○	○	○	○	○	○

Presetting menu items

Menu item	Presetting position number						Default by resetting*
	1	2	3	4	5	6	
EXPOSURE MODE	○	○	○	○	○	○	FULL AUTO
EX-COMP	○	○	○	○	○	○	OFF
SPOT AE	○	×	×	×	×	×	—
FOCUS AUTO/MANUAL	○	○	○	○	○	○	ON
NORMAL, INTERVAL, ZOOM Trg	○	×	×	×	×	×	NORMAL**
WHITE BALANCE MODE	○	○	○	○	○	○	WB. AUTO
WHITE BALANCE MANUAL R./B. GAIN	○	○	○	○	○	○	WB. AUTO
D-ZOOM	○	○	○	○	○	○	D-ZOOM ON
PAN-TILT LIMIT	○	×	×	×	×	×	—
PICTURE EFFECT	○	×	×	×	×	×	OFF**
WIDE	○	×	×	×	×	×	OFF**
APERTURE	○	○	○	○	○	○	8
DATA MIX	○	×	×	×	×	×	—
IR-RECEIVE	○	×	×	×	×	×	—
IMG-FLIP	○	×	×	×	×	×	—
PAN REVERSE	○	×	×	×	×	×	—
TILT REVERSE	○	×	×	×	×	×	—
DISPLAY INFO	○	×	×	×	×	×	—
ANALOG OUPUT 1	○	×	×	×	×	×	—
RGB/SYNC SELECT	○	×	×	×	×	×	—
ANALOG OUTPUT 2	○	×	×	×	×	×	—

* Default by resetting “—” means that the camera starts with the setting stored in Position 1, but you cannot reset the setting using the RESET button.

** The default setting is obtained by resetting Position 1.

○ : Setting items retained in memory when the power is turned off and on again. The camera starts with these settings.
 × : Setting items cleared from the memory when the power is turned off and on.

Specifications

System

Video signal	BRC-300: NTSC color, JEITA standards BRC-300P: PAL color, CCIR standards
Synchronization	Internal/external synchronization automatically switched
Picture element	1/4.7 type, 3CCD (Advanced HAD) Total picture elements: Approx. 1,070,000 pixels Effective picture elements: Approx. 1,020,000 pixels
Lens	12× (optical), 4× (digital) f = 3.6 to 43.2 mm, F1.6 to F2.8
Horizontal angle	3.3 to 37.8 degrees (4:3) 4.0 to 45.4 degrees (16:9)
Minimum object distance	300 mm (11 7/8 inches) (WIDE end)
Minimum illumination	7 lux (F1.6) with 25 IRE
Shutter speed	1/4 to 1/10,000 sec. (BRC-300) 1/3 to 1/10,000 sec. (BRC-300P)
Horizontal resolution	600 TV (WIDE end, 4:3 mode)
Video S/N	50 dB
Pan/tilt action	Horizontal: ±170 degrees Maximum panning speed: 60 degrees/sec. Minimum panning speed: 0.25 degrees/sec. Vertical: +90 degrees, -30 degrees Maximum tilting speed: 60 degrees/sec. Minimum tilting speed: 0.25 degrees/sec.

Input/output connectors

Video output	BNC type (1), 1 Vp-p, 75 ohms unbalanced, sync negative
S-video output	Mini DIN 4-pin type (1) Y: 1 Vp-p, sync negative C: same level as the chroma level of video output, 75 ohms
Control input/output	VISCA RS-232C IN: Mini DIN 8-pin type VISCA RS-232C OUT: Mini DIN 8-pin type VISCA RS-422: 9-pin type

Control signal format	9600 bps/38400 bps Data: 8 bit Stop bit: 1
Power connector	JEITA type4 (DC IN 12V)

General

Input voltage	12 V DC (10.8 to 13.2 V DC)
Current consumption	1.8 A max. (at 12 V DC), 21.6 W without optional interface cards
Operating temperature	0°C to +35°C (32°F to 95°F)
Storage temperature	-20°C to +60°C (-4°F to 140°F)
Dimensions	Video camera: 180 × 210.1 × 205 mm (7 1/8 × 8 3/8 × 8 1/8 inches) (w/h/d) (excluding protruding parts) Remote Commander: 56 × 26 × 210 mm (2 1/4 × 1 1/16 × 8 3/8 inches) (w/h/d)
Mass	Video camera: Approx. 2.5 kg (5 lb 8 oz) Remote Commander: 110 g (3.9 oz)
Installation angle	Less than ±15 degrees to the horizontal surface

Supplied accessories

AC power adaptor MPA-AC1 (Sony) (1)
AC power cord (1)
Remote Commander (1)
Ceiling bracket (A) (1)
Ceiling bracket (B) (1)
Wire rope (1)
Screws (+ M3 × 8) (7)
RS-422 connector plug (1)
Operating Instructions (1)

Design and specifications are subject to change without notice.

Dimensions

BRC-300/300P Video Camera

Top

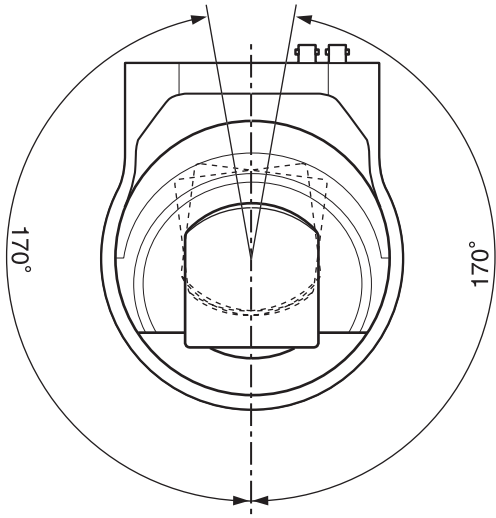

Front

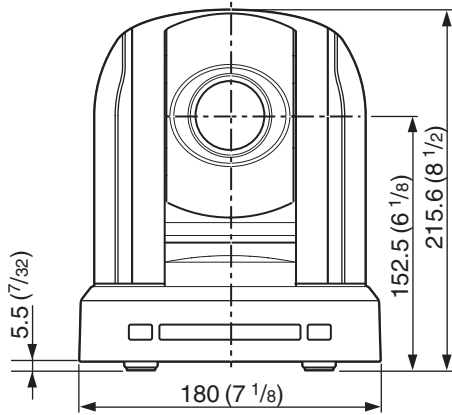

Side

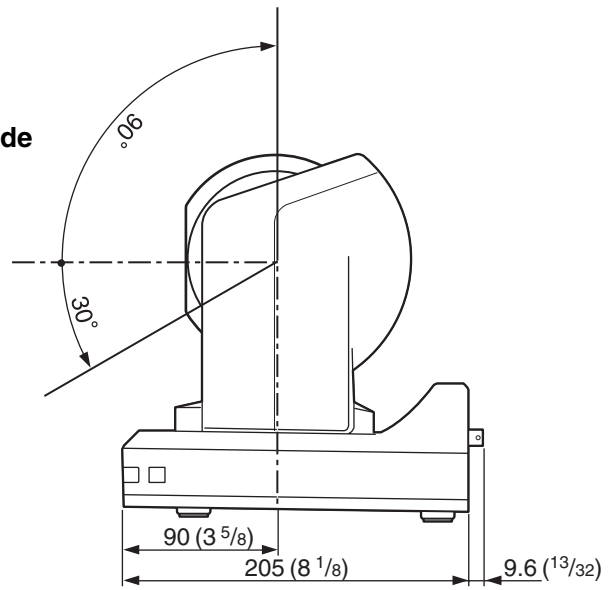

Bottom

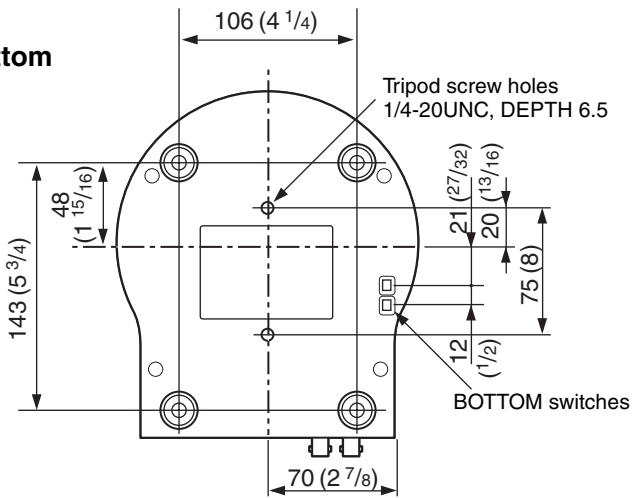

Unit: mm (inches)

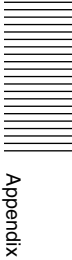

RM-BR300 Remote Control Unit

Top

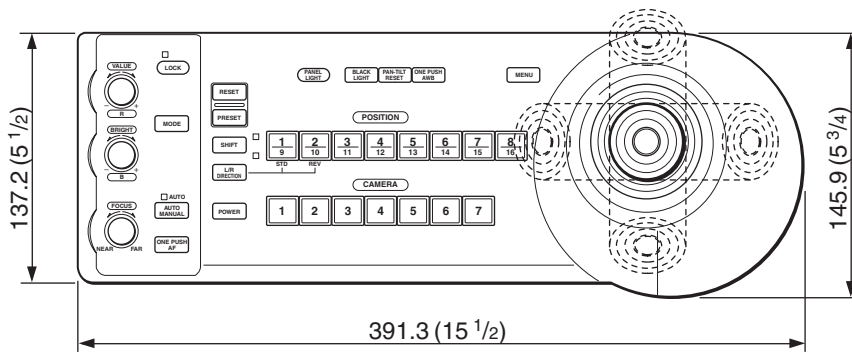

Front

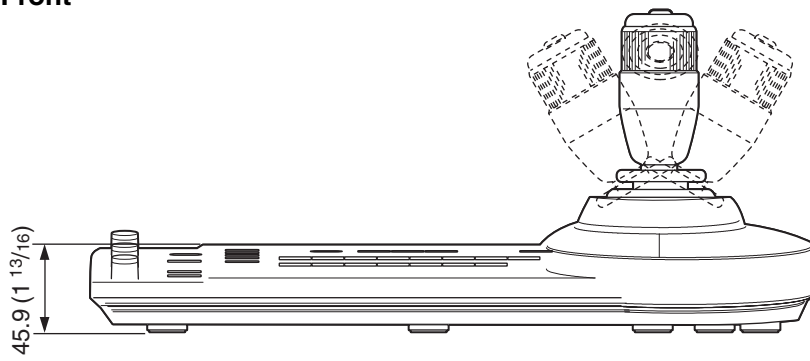

Side

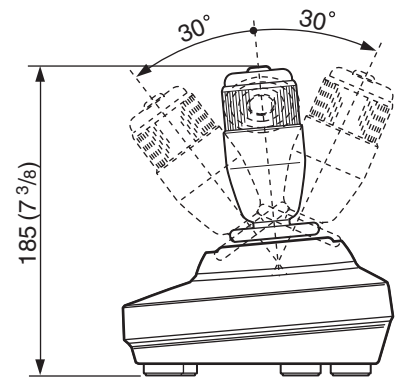

Bottom

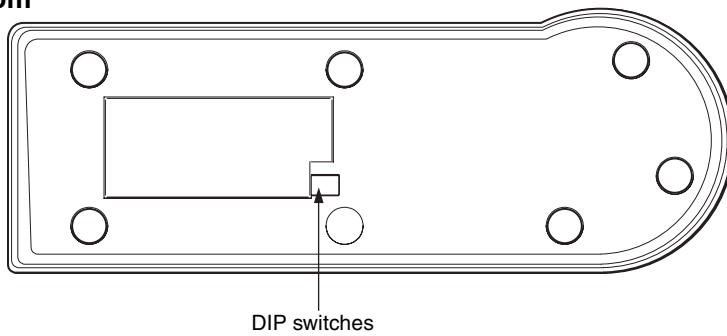

Unit: mm (inches)

BRU-300/300P Optical Multiplex Unit

Top

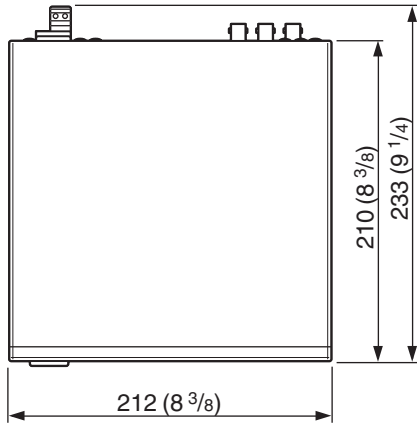

Side

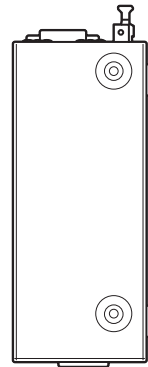

Front



Unit: mm (inches)

Pin Assignments

BRC-300/300P Video Camera

VISCA RS-422 connector (connector plug 9-pin)

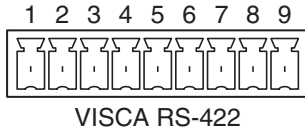

Pin No.	Function
1	RXD OUT-
2	RXD OUT+
3	TXD OUT-
4	TXD OUT+
5	GND
6	RXD IN-
7	RXD IN+
8	TXD IN-
9	TXD IN+

VISCA RS-232C IN connector (mini-DIN 8-pin, female)



Pin No.	Function
1	DTR IN
2	DSR IN
3	TXD IN
4	GND
5	RXD IN
6	GND
7	SIRCS OUT *
8	No Connection

* The SIRCS OUT function is selectable with the BOTTOM switch on the bottom of the camera.

VISCA RS-232C OUT connector (mini DIN 8-pin, female)

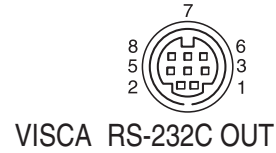

Pin No.	Function
1	DTR OUT
2	DSR OUT
3	TXD OUT
4	GND
5	RXD OUT
6	GND
7	No Connection
8	No Connection

RM-BR300 Remote Control Unit (optional)

VISCA RS-232C output connector (mini DIN 8-pin, female)

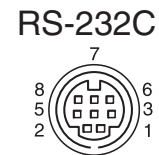

Pin No.	Function
1	No Connection
2	No Connection
3	TXD IN
4	GND
5	RXD IN
6	GND
7	No Connection
8	No Connection

VISCA RS-422 connector (connector plug, 9-pin)

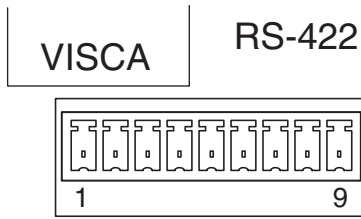

Pin No.	Function
1	No Connection
2	No Connection
3	No Connection
4	No Connection
5	GND
6	RXD IN-
7	RXD IN+
8	TXD IN-
9	TXD IN+

TALLY/CONTACT connector (connector plug, 9-pin)

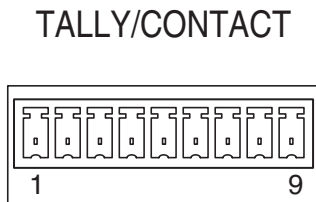

Pin No.	Function
1	CAMERA1
2	CAMERA2
3	CAMERA3
4	CAMERA4
5	CAMERA5
6	CAMERA6
7	CAMERA7
8	GND
9	GND

BRU-300/300P Optical Multiplex Unit (optional)

VISCA RS-232C IN connector (mini DIN 8-pin, female)

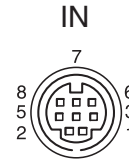

VISCA RS-232C

Pin No.	Function
1	DTR IN
2	DSR IN
3	TXD IN
4	GND
5	RXD IN
6	GND
7	No Connection
8	No Connection

VISCA RS-232C OUT connector (mini DIN 8-pin, female)

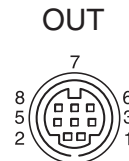

VISCA RS-232C

Pin No.	Function
1	DTR OUT
2	DSR OUT
3	TXD OUT
4	GND
5	RXD OUT
6	GND
7	No Connection
8	No Connection

VISCA RS-422 connector (connector plug, 9-pin)

VISCA RS-422

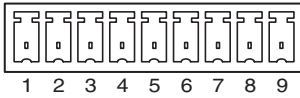

Pin No.	Function
1	RXD OUT-
2	RXD OUT+
3	TXD OUT-
4	TXD OUT+
5	GND
6	RXD IN-
7	RXD IN+
8	TXD IN-
9	TXD IN+

BRBK-301 Analog RGB Component Card (optional)

Analog video output connector (D-sub 9-pin)

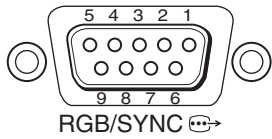

Pin No.	Function			
	At RGB/ VBS setting	At RGB/ Y/C setting	At YCrCb/ VBS setting	At YCrCb/ Y/C setting
1	RGB GND	RGB GND	RGB GND	RGB GND
2	RGB GND	RGB GND	RGB GND	RGB GND
3	R	R	Cr	Cr
4	G	G	Y	Y
5	B	B	Cb	Cb
6	Composite	Y	Composite	Y
7	SYNC	SYNC	SYNC	SYNC
8	SYNC GND	SYNC GND	SYNC GND	SYNC GND
9	No Connection	C	No Connection	C

Wiring Diagram of VISCA RS-422 Connection

Third to Seventh BRC-300/300P or BRU-300/300P

VISCA RS-422 connector

1	RXD OUT -
2	RXD OUT +
3	TXD OUT -
4	TXD OUT +
5	GND
6	RXD IN -
7	RXD IN +
8	TXD IN -
9	TXD IN +

Second BRC-300/300P or BRU-300/300P

VISCA RS-422 connector

1	RXD OUT -
2	RXD OUT +
3	TXD OUT -
4	TXD OUT +
5	GND
6	RXD IN -
7	RXD IN +
8	TXD IN -
9	TXD IN +

First BRC-300/300P camera or BRU-300/300P Optical Multiplex Unit

VISCA RS-422 connector

1	RXD OUT -
2	RXD OUT +
3	TXD OUT -
4	TXD OUT +
5	GND
6	RXD IN -
7	RXD IN +
8	TXD IN -
9	TXD IN +

RM-BR300 Remote Control Unit

VISCA RS-422 connector

1	NC
2	NC
3	NC
4	NC
5	GND
6	RXD IN -
7	RXD IN +
8	TXD IN -
9	TXD IN +

NC = No Connection

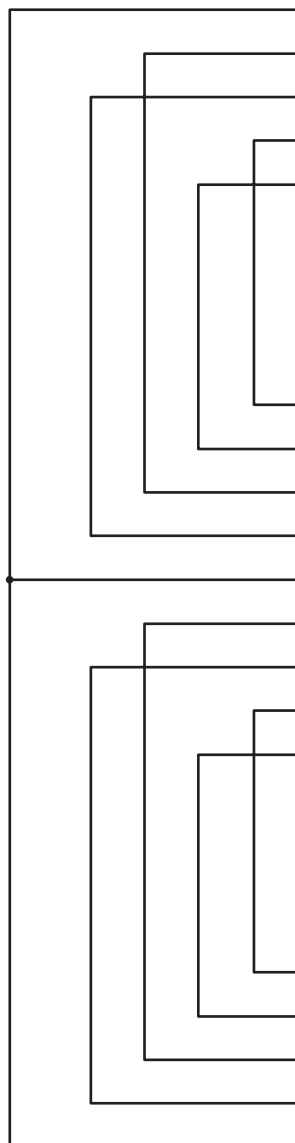

Appendix

Using the VISCA RS-422 Connector Plug

- 1 Insert a wire (AWG Nos. 28 to 18) into the desired wire opening on the VISCA RS-422 connector plug, and tighten the screw for that wire using a flat-head screwdriver.

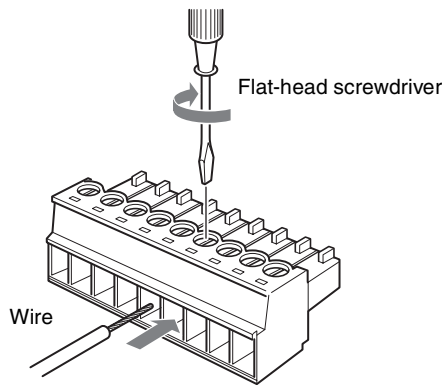

- 2 Insert the VISCA RS-422 connector plug into the VISCA RS-422 connector.

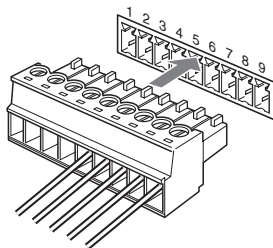

To remove the connector plug

Grasp both ends of the VISCA RS-422 connector plug and pull it out as shown in the illustration.

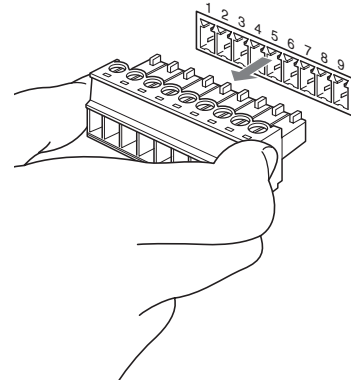

Notes

- In order to stabilize the voltage level of the signal, connect both ends to GND.
- When the connections using the VISCA RS-422 connectors are made, the VISCA RS-232C connection is not available.
- The maximum connection distance with the VISCA RS-422 connection is approximately 1,200 m (3,937 feet).



Printed on 100% recycled paper.